

Operation Manual

R-Series - SSI

Magnetostrictive Linear Position Sensors



Table of contents

1. Introduction	3
1.1 Purpose and use of this manual	3
1.2 Used symbols and warnings	3
2. Safety instructions	3
2.1 Intended use	3
2.2 Foreseeable misuse	3
2.3 Installation, commissioning and operation	4
2.4 Safety instructions for use in explosion-hazardous areas	4
2.5 Warranty	4
2.6 Return	4
3. Identification	5
3.1 Order code of Temposonics® RP	5
3.2 Order code of Temposonics® RH	7
3.3 Order code of Temposonics® RD4	9
3.4 Order code of Temposonics® RT4	11
3.5 Order code of Temposonics® RF	13
3.6 Nameplate	15
3.7 Approvals	15
3.8 Scope of delivery	15
4. Product description and commissioning	16
4.1 Functionality and system design	16
4.2 Styles and installation of Temposonics® RP	17
4.3 Styles and installation of Temposonics® RH	18
4.4 Styles and installation of Temposonics® RD4	21
4.4.1 Installation of RD4 with threaded flange	24
4.4.2 Installation of RD4 with pressure fit flange	25
4.4.3 Installation of RD4's sensor electronics housing	26
4.5 Styles and installation of Temposonics® RT4	27
4.5.1 Installation of RT4 with threaded flange	29
4.5.2 Installation of RT4's sensor electronics housing	30
4.6 Styles and installation of Temposonics® RF	31
4.7 Magnet installation	33
4.8 Replacement of sensor	37
4.9 Electrical connections	38
4.10 Frequently ordered accessories	39
5. Operation	42
5.1 Getting started	42
5.2 Programming and configuration	42
6. Maintenance and troubleshooting	46
6.1 Error conditions, troubleshooting	46
6.2 Maintenance	46
6.3 Repair	46
6.4 List of spare parts	46
6.5 Transport and storage	46
7. Removal from service / dismantling	46
8. Technical data	47
8.1 Technical data of Temposonics® RP	47
8.2 Technical data of Temposonics® RH	49
8.3 Technical data of Temposonics® RD4	51
8.4 Technical data of Temposonics® RT4	53
8.5 Technical data of Temposonics® RF	55
9. Appendix	57

1. Introduction

1.1 Purpose and use of this manual

Before starting the operation of Temposonics® position sensors, read this documentation thoroughly and follow the safety information. Keep the manual for future reference!

The content of this technical documentation and of its appendix is intended to provide information on mounting, installation and commissioning by qualified automation personnel ¹ or instructed service technicians who are familiar with the project planning and dealing with Temposonics® position sensors.

1.2 Used symbols and warnings

Warnings are intended for your personal safety and for avoidance of damage to the described product or connected devices. In this documentation, safety information and warnings to avoid dangers that might affect the life and health of operating or service personnel or cause material damage are highlighted by the preceding pictogram, which is defined below.

Symbol	Meaning
NOTICE	This symbol is used to point to situations that may lead to material damage, but not to personal injury.

2. Safety instructions

2.1 Intended use

This product may be used only for the applications defined under item 1 and only in conjunction with the third-party devices and components recommended or approved by temposonics. As a prerequisite of proper and safe operation, the product requires correct transport, storage, mounting and commissioning and must be operated with utmost care.

- The sensor systems of all Temposonics® series are intended exclusively for measurement tasks encountered in industrial, commercial and laboratory applications. The sensors are considered as system accessories and must be connected to suitable evaluation electronics, e.g. a PLC, IPC, indicator or other electronic control unit.

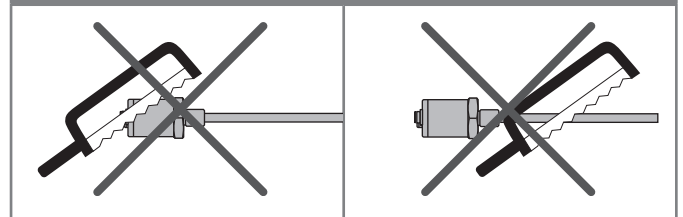
^{1/} The term qualified technical personnel characterizes persons who:

- are familiar with the safety concepts of automation technology applicable to the particular project,

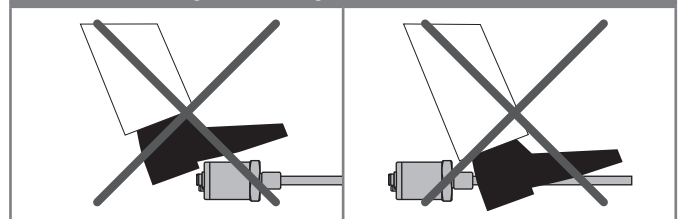
2.2 Forseeable misuse

Forseeable misuse	Consequence
Wrong sensor connection	The sensor will not work properly or will be destroyed
Operate the sensor out of the operating temperature range	No signal output The sensor can be damaged
Power supply is out of the defined range	Signal output is wrong / no signal output / the sensor will be damaged
Position measurement is influenced by an external magnetic field	Signal output is wrong
Cables are damaged	Short circuit – the sensor can be destroyed / sensor does not respond
Spacers are missing / are installed in a wrong order	Error in position measurement
Wrong connection of ground / shield	Signal output is disturbed The electronics can be damaged
Use of a magnet that is not certified by Temposonics	Error in position measurement

Do not reprocess the sensor afterwards.
→ The sensor might be damaged.



Do not step on the sensor.
→ The sensor might be damaged.



- are competent in the field of electromagnetic compatibility (EMC),
- have received adequate training for commissioning and service operations
- are familiar with the operation of the device and know the information required for correct operation provided in the product documentation.

2.3 Installation, commissioning and operation

The position sensors must be used only in technically safe condition. To maintain this condition and to ensure safe operation, installation, connection and service, work may be performed only by qualified technical personnel.

If danger of injury to persons or of damage to operating equipment is caused by sensor failure or malfunction, additional safety measures such as plausibility checks, limit switches, EMERGENCY STOP systems, protective devices etc. are required. In the event of trouble, shut down the sensor and protect it against accidental operation.

Safety instructions for commissioning

To maintain the sensor's operability, it is mandatory to follow the instructions given below.

1. Protect the sensor against mechanical damage during installation and operation.
2. Do not open or dismantle the sensor.
3. Connect the sensor very carefully and pay attention to the polarity of connections and power supply.
4. Use only approved power supplies.
5. It is indispensable to ensure that the specified permissible limit values of the sensor for operating voltage, environmental conditions, etc. are met.
6. Check the function of the sensor regularly and provide documentation of the checks.
7. Before applying power, ensure that nobody's safety is jeopardized by starting machines.

2.4 Safety instructions for use in explosion-hazardous areas

The sensor is not suitable for operation in explosion-hazardous areas.

2.5 Warranty

Temposonics grants a warranty period for the Temposonics® position sensors and supplied accessories relating to material defects and faults that occur despite correct use in accordance with the intended application^{2/}. The MTS Sensors obligation is limited to repair or replacement of any defective part of the unit. No warranty can be provided for defects that are due to improper use or above average stress of the product, as well as for wear parts. Under no circumstances will MTS Sensors accept liability in the event of offense against the warranty rules, no matter if these have been assured or expected, even in case of fault or negligence of the company.

MTS Sensors explicitly excludes any further warranties. Neither the company's representatives, agents, dealers nor employees are authorized to increase or change the scope of warranty.

2.6 Return

For diagnostic purposes, the sensor can be returned to Temposonics. Any shipment cost is the responsibility of the sender^{2/}. For a corresponding form, see chapter "9. Appendix" on page 57.

^{2/} See also applicable MTS Sensors terms of sales and delivery on

www.temposonics.com

3. Identification

3.1 Order code of Temposonics® RP

1	2	3	4	5	6	7	8	9	10	11	12	13	14	15	16	17	18	19	20	21	22	
R	P											S										
a		b	c					d			e	f										

20, 21, 22: Optional

a	Sensor model	
R	P	Profile

b	Design
G	Magnet slider, joint on top, backlash free (part no. 253 421)
M	U-magnet, OD33 (part no. 251 416-2)
S	Magnet slider, joint on top (part no. 252 182)
V	Magnet slider, joint at front (part no. 252 184)

c	Stroke length				
X	X	X	X	M	0025...5080 mm
X	X	X	X	U	001.0...200.0 in.

Standard stroke length (mm)*

Stroke length	Ordering steps
25 ... 500 mm	25 mm
500...2500 mm	50 mm
2500...5080 mm	100 mm

Standard stroke length (in.)*

Stroke length	Ordering steps
1 ... 20 in.	1 in.
20...100 in.	2 in.
100...200 in.	4 in.

d	Connection type		
D	7	0	M16 (7 pin) male connector See "Frequently ordered accessories" for cable connector specifications
F	X	X	XX m PUR cable (part no. 530 045) F01...F10 (1...10 m / 3...33 ft.) ³ See "Frequently ordered accessories" for cable specifications
H	X	X	XX m PUR cable (part no. 530 052) H01...H10 (1...10 m / 3...33 ft.) ³ See "Frequently ordered accessories" for cable specifications
M	S	0	MS0 (10 pin) male connector
P	X	X	XX m TMPU cable (part no. 530 029) P01...P10 (1...10 m / 3...33 ft.) ³ See "Frequently ordered accessories" for cable specifications
R	X	X	XX m PVC cable (part no. 530 032) R01...R10 (1...10 m / 3...33 ft.) ³ See "Frequently ordered accessories" for cable specifications

e	Operating voltage
1	+24 VDC (-15 / +20 %)
A	+24 VDC (-15 / +20 %), vibration resistant (stroke length 25...2000 mm / 1...79 in.)

f	Output
S	(14) (15) (16) (17) (18) (19) (20) (21) (22) = Synchronous Serial Interface
Data length (box no. 14)	
1	25 bit
2	24 bit
3	26 bit
Output format (box no. 15)	
B	Binary
G	Gray
Resolution (box no. 16)	
1	0.005 mm
2	0.01 mm
3	0.05 mm
4	0.1 mm
5	0.02 mm
6	0.002 mm
8	0.001 mm
9	0.0005 mm
Filtering performance (box no. 17)	
A	No filter + error delay (4 cycles)
C	No filter + error delay (8 cycles)
1	Standard (no filters)
8	Noise reduction filter (8 measurements)
D	No filter + error delay (10 cycles)
G	Noise reduction filter (8 measurements) + error delay (10 cycles)
K	Peak reduction filter (8 measurements)
N	Peak reduction filter (8 measurements) + error delay (10 cycles)

f Continued on next page

* / Non standard stroke lengths are available; must be encoded in 5 mm / 0.1 in. increments

³ / Encode in meters if using metric stroke length. Encode in feet if using US customary stroke length

f		Output (continued)
Signal options (box no. 18, 19)		
0	0	Measuring direction forward, asynchronous mode
0	1	Measuring direction reverse, asynchronous mode
0	2	Measuring direction forward, synchronous mode 1
0	5	Measuring direction forward, asynchronous mode, bit 25 = alarm, bit 26 = parity even
1	6	Measuring direction forward, asynchronous mode, internal linearization
9	9	Write "9" in box no. 18 and 19 for using further combinations in boxes 20, 21, 22.
Measurement contents (optional: box no. 20)		
Note: Choose "9" in box no. 18 and 19.		
1		Position measurement
2		Differentiation measurement ⁴
3		Velocity measurement
4		Position measurement + temperature measurement (only with data length = 24 bit)
5		Differentiation measurement ⁴ + temperature measurement (only with data length = 24 bit)
6		Velocity measurement + temperature measurement (only with data length = 24 bit)
Direction and sync. mode (optional: box no. 21)		
Note: Choose "9" in box no. 18 and 19.		
1		Measuring direction forward, asynchronous mode
2		Measuring direction forward, synchronous mode 1
3		Measuring direction forward, synchronous mode 2
4		Measuring direction forward, synchronous mode 3
5		Measuring direction reverse, asynchronous mode
6		Measuring direction reverse, synchronous mode 1
7		Measuring direction reverse, synchronous mode 2
8		Measuring direction reverse, synchronous mode 3
Internal linearization & diagnostics (optional: box no. 22)		
Note: Choose "9" in box no. 18 and 19.		
0		No further options
1		Internal linearization
2		Additional alarm bit + parity even bit (not available for temperature output, only with data length = 24 bit)
4		Additional alarm bit + parity even bit and internal linearization (not available for temperature output, only with data length = 24 bit)

4/ You need a second magnet for differentiation measurement

3.2 Order code of Temposonics® RH

1	2	3	4	5	6	7	8	9	10	11	12	13	14	15	16	17	18	19	20	21	22	
R	H											S										
a		b	c					d			e	f										

20, 21, 22: Optional

a	Sensor model	
R	H	Rod

b	Design
B	Base unit
D	Threaded flange M18×1.5-6g (bushing on rod end)
H	Threaded flange ¾"-16 UNF-3A (with fluoroelastomer housing-seal)
J	Threaded flange M22×1.5-6g (rod Ø 12.7 mm, 800 bar)
M	Threaded flange M18×1.5-6g (standard)
R	Threaded flange M18×1.5-6g (thread M4 at rod end)
S	Threaded flange ¾"-16 UNF-3A (standard)
T	Threaded flange ¾"-16 UNF-3A (with raised-face)
U	Threaded flange ¾"-16 UNF-3A (with raised-face & fluoroelastomer housing-seal)
V	Threaded flange M18×1.5-6g (with fluoroelastomer housing-seal)

c	Stroke length				
X	X	X	X	M	0025...7620 mm
X	X	X	X	U	001.0...300.0 in.

Standard stroke length (mm)*

Stroke length	Ordering steps
25 ... 500 mm	5 mm
500 ... 750 mm	10 mm
750...1000 mm	25 mm
1000...2500 mm	50 mm
2500...5000 mm	100 mm
5000...7620 mm	250 mm

Standard stroke length (in.)*

Stroke length	Ordering steps
1 ... 20 in.	0.2 in.
20 ... 30 in.	0.4 in.
30 ... 40 in.	1.0 in.
40...100 in.	2.0 in.
100...200 in.	4.0 in.
200...300 in.	10.0 in.

d	Connection type		
D	7	0	M16 (7 pin) male connector See "Frequently ordered accessories" for cable connector specifications
F	X	X	XX m PUR cable (part no. 530 045) F01...F10 (1...10 m / 3...33 ft.) ⁵ See "Frequently ordered accessories" for cable specifications
H	X	X	XX m PUR cable (part no. 530 052) H01...H10 (1...10 m / 3...33 ft.) ⁵ See "Frequently ordered accessories" for cable specifications
M	S	0	MS0 (10 pin) male connector
P	X	X	XX m TMPU cable (part no. 530 029) P01...P10 (1...10 m / 3...33 ft.) ⁵ See "Frequently ordered accessories" for cable specifications
R	X	X	XX m PVC cable (part no. 530 032) R01...R10 (1...10 m / 3...33 ft.) ⁵ See "Frequently ordered accessories" for cable specifications

e	Operating voltage	
1	+24 VDC (-15 / +20 %)	
A	+24 VDC (-15 / +20 %), vibration resistant (stroke length 25...2000 mm / 1...79 in.)	

f See next page

*/ Non standard stroke lengths are available; must be encoded in 5 mm / 0.1 in. increments

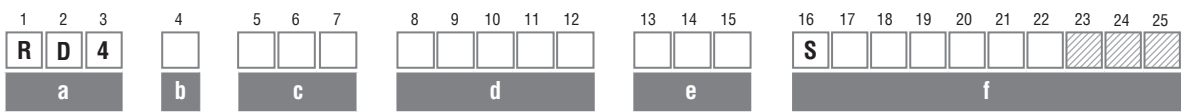
5/ Encode in meters if using metric stroke length. Encode in feet if using US customary stroke length

f	Output
S (14) (15) (16) (17) (18) (19) (20) (21) (22)	= Synchronous Serial Interface
Data length (box no. 14)	
1	25 bit
2	24 bit
3	26 bit
Output format (box no. 15)	
B	Binary
G	Gray
Resolution (box no. 16)	
1	0.005 mm
2	0.01 mm
3	0.05 mm
4	0.1 mm
5	0.02 mm
6	0.002 mm
8	0.001 mm
9	0.0005 mm
Filtering performance (box no. 17)	
A	No filter + error delay (4 cycles)
C	No filter + error delay (8 cycles)
1	Standard (no filters)
8	Noise reduction filter (8 measurements)
D	No filter + error delay (10 cycles)
G	Noise reduction filter (8 measurements) + error delay (10 cycles)
K	Peak reduction filter (8 measurements)
N	Peak reduction filter (8 measurements) + error delay (10 cycles)
Signal options (box no. 18, 19)	
0 0	Measuring direction forward, asynchronous mode
0 1	Measuring direction reverse, asynchronous mode
0 2	Measuring direction forward, synchronous mode 1
0 5	Measuring direction forward, asynchronous mode, bit 25 = alarm, bit 26 = parity even
1 6	Measuring direction forward, asynchronous mode, internal linearization
9 9	Write "9" in box no. 18 and 19 for using further combinations in boxes 20, 21, 22 .

f	Output (continued)
Measurement contents (optional: box no. 20)	
Note: Choose "9" in box no. 18 and 19.	
1	Position measurement
2	Differentiation measurement ⁶
3	Velocity measurement
4	Position measurement + temperature measurement (only with data length = 24 bit)
5	Differentiation measurement ⁶ + temperature measurement (only with data length = 24 bit)
6	Velocity measurement + temperature measurement (only with data length = 24 bit)
Direction and sync. mode (optional: box no. 21)	
Note: Choose "9" in box no. 18 and 19.	
1	Measuring direction forward, asynchronous mode
2	Measuring direction forward, synchronous mode 1
3	Measuring direction forward, synchronous mode 2
4	Measuring direction forward, synchronous mode 3
5	Measuring direction reverse, asynchronous mode
6	Measuring direction reverse, synchronous mode 1
7	Measuring direction reverse, synchronous mode 2
8	Measuring direction reverse, synchronous mode 3
Internal linearization & diagnostics (optional: box no. 22)	
Note: Choose "9" in box no. 18 and 19.	
0	No further options
1	Internal linearization
2	Additional alarm bit + parity even bit (not available for temperature output, only with data length = 24 bit)
4	Additional alarm bit + parity even bit and internal linearization (not available for temperature output, only with data length = 24 bit)

6/ You need a second magnet for differentiation measurement

3.3 Order code of Temposonics® RD4



23, 24, 25: Optional

a	Sensor model		
R	D	4	Detached sensor electronics

b	Design
C	Threaded flange M18×1.5-6g, A/F 46
D	Threaded flange ¾"-16 UNF-3A, A/F 46
G	Threaded flange M18×1.5-6g, A/F 24
M	Threaded flange M18×1.5-6g, A/F 23
S	Pressure fit flange Ø 26.9 mm f6
T	Threaded flange ¾"-16 UNF-3A, A/F 23

c	Integral cable of sensor rod		
For side cable entry on sensor electronics housing			
D	1	S	PUR cable with M16 connector, length 250 mm (9.8 in.)
D	2	S	PUR cable with M16 connector, length 400 mm (15.7 in.)
D	3	S	PUR cable with M16 connector, length 600 mm (23.6 in.)
For bottom cable entry on sensor electronics housing			
R	2	B	PUR cable / wires with flat connector, length 65 mm (2.6 in.)
R	4	B	PUR cable / wires with flat connector, length 170 mm (6.7 in.)
R	5	B	PUR cable / wires with flat connector, length 230 mm (9.1 in.)
R	6	B	PUR cable / wires with flat connector, length 350 mm (13.8 in.)

d	Stroke length				
X	X	X	X	M	Flange »C« / »D«, »G«, »M« / »T«: 0025...5080 mm Flange »S«: 0025...2540 mm
X	X	X	X	U	Flange »C« / »D«, »G«, »M« / »T«: 001.0...200.0 in. Flange »S«: 001.0...100.0 in.

Standard stroke length (mm)*

Stroke length	Ordering steps
25 ... 500 mm	5 mm
500 ... 750 mm	10 mm
750...1000 mm	25 mm
1000...2500 mm	50 mm
2500...5080 mm	100 mm

Standard stroke length (in.)*

Stroke length	Ordering steps
1 ... 20 in.	0.2 in.
20 ... 30 in.	0.4 in.
30 ... 40 in.	1.0 in.
40...100 in.	2.0 in.
100...200 in.	4.0 in.

e	Connection type		
D	7	0	M16 (7 pin) male connector See "Frequently ordered accessories" for cable connector specifications
F	X	X	XX m PUR cable (part no. 530 045) F01...F10 (1...10 m / 3...33 ft.) ⁷ See "Frequently ordered accessories" for cable specifications
H	X	X	XX m PUR cable (part no. 530 052) H01...H10 (1...10 m / 3...33 ft.) ⁷ See "Frequently ordered accessories" for cable specifications
M	S	0	MS0 (10 pin) male connector
P	X	X	XX m TMPU cable (part no. 530 029) P01...P10 (1...10 m / 3...33 ft.) ⁷ See "Frequently ordered accessories" for cable specifications
R	X	X	XX m PVC cable (part no. 530 032) R01...R10 (1...10 m / 3...33 ft.) ⁷ See "Frequently ordered accessories" for cable specifications

Operating voltage

+24 VDC (-15 / +20 %); Standard, not indicated in order code

f Continued on next page

*/ Non standard stroke lengths are available; must be encoded in 5 mm / 0.1 in. increments

7/ Encode in meters if using metric stroke length. Encode in feet if using US customary stroke length

f	Output
S (17) (18) (19) (20) (21) (22) (23) (24) (25) = Synchronous Serial Interface	
Data length (box no. 17)	
1	25 bit
2	24 bit
3	26 bit
Output format (box no. 18)	
B	Binary
G	Gray
Resolution (box no. 19)	
1	0.005 mm
2	0.01 mm
3	0.05 mm
4	0.1 mm
5	0.02 mm
6	0.002 mm
8	0.001 mm
Filtering performance (box no. 20)	
A	No filter + error delay (4 cycles)
C	No filter + error delay (8 cycles)
1	Standard (no filters)
8	Noise reduction filter (8 measurements)
D	No filter + error delay (10 cycles)
G	Noise reduction filter (8 measurements) + error delay (10 cycles)
K	Peak reduction filter (8 measurements)
N	Peak reduction filter (8 measurements) + error delay (10 cycles)
Signal options (box no. 21, 22)	
0	0 Measuring direction forward, asynchronous mode
0	1 Measuring direction reverse, asynchronous mode
0	2 Measuring direction forward, synchronous mode 1
0	5 Measuring direction forward, asynchronous mode, bit 25 = alarm, bit 26 = parity even
9	9 Write "9" in box no. 21 and 22 for using further combinations in boxes 23, 24, 25 .

f	Output (continued)
Measurement contents (optional: box no. 23) Note: Choose "9" in box no. 21 and 22.	
1	Position measurement
2	Differentiation measurement ⁸
3	Velocity measurement
4	Position measurement + temperature measurement (only with data length = 24 bit)
5	Differentiation measurement ⁸ + temperature measurement (only with data length = 24 bit)
6	Velocity measurement + temperature measurement (only with data length = 24 bit)
Direction and sync. mode (optional: box no. 24) Note: Choose "9" in box no. 21 and 22.	
1	Measuring direction forward, asynchronous mode
2	Measuring direction forward, synchronous mode 1
3	Measuring direction forward, synchronous mode 2
4	Measuring direction forward, synchronous mode 3
5	Measuring direction reverse, asynchronous mode
6	Measuring direction reverse, synchronous mode 1
7	Measuring direction reverse, synchronous mode 2
8	Measuring direction reverse, synchronous mode 3
Only available for flanges »C« / »D«, »G« & »M« / »T« Internal linearization & diagnostics (optional: box no. 25) Note: Choose "9" in box no. 21 and 22.	
0	No further options
1	Internal linearization
2	Additional alarm bit + parity even bit (not available for temperature output, only with data length = 24 bit)
4	Additional alarm bit + parity even bit and internal linearization (not available for temperature output, only with data length = 24 bit)

8/ You need a second magnet for differentiation measurement

3.4 Order code of Temposonics® RT4

1	2	3	4	5	6	7	8	9	10	11	12	13	14	15	16	17	18	19	20	21	22	23	24	25	
R	T	4		B		E									S										
a			b	c			d					e			f										

23, 24, 25: Optional

a	Sensor model	
R	T	4
Redundant with detached electronics		

b	Design
D	Threaded flange with flat-face, 3/4"-16 UNF-3A
M	Threaded flange with flat-face, M18×1.5-6g
T	Threaded flange with raised-face, 3/4"-16 UNF-3A

c	Integral cable of sensor rod		
For side cable entry on sensor electronics housing			
B	1	E	250 mm (9.8 in.) Santoprene® cable, hanging connector
B	2	E	400 mm (15.7 in.) Santoprene® cable, hanging connector
B	3	E	600 mm (23.6 in.) Santoprene® cable, hanging connector

d	Stroke length				
X	X	X	X	M	0025...2540 mm
X	X	X	X	U	001.0...100.0 in

Standard stroke length (mm)*

Stroke length	Ordering steps
25 ... 500 mm	5 mm
500 ... 750 mm	10 mm
750...1000 mm	25 mm
1000...2540 mm	50 mm

Standard stroke length (in.)*

Stroke length	Ordering steps
1 ... 20 in.	0.2 in.
20 ... 30 in.	0.4 in.
30 ... 40 in.	1.0 in.
40...100 in.	2.0 in.

e	Connection type		
D	7	0	M16 (7 pin) male connector See "Frequently ordered accessories" for cable connector specifications
F	X	X	XX m PUR cable (part no. 530 045) F01...F30 (1...30 m / 3...98 ft.) ⁹ See "Frequently ordered accessories" for cable specifications
M	S	0	MS (10 pin) male connector
P	X	X	XX m TMPU cable (part no. 530 029) P01...P30 (1...30 m / 3...98 ft.) ⁹ See "Frequently ordered accessories" for cable specifications
R	X	X	XX m PVC cable (part no. 530 032) R01...R30 (1...30 m / 3...98 ft.) ⁹ See "Frequently ordered accessories" for cable specifications

Operating voltage

+24 VDC (-15 / +20 %); Standard, not indicated in order code

f	Output
S	(17) (18) (19) (20) (21) (22) (23) (24) (25) = Synchronous Serial Interface
Data length (box no. 17)	
1	25 bit
2	24 bit
3	26 bit
Output format (box no. 18)	
B	Binary
G	Gray
Resolution (box no. 19)	
1	0.005 mm
2	0.01 mm
3	0.05 mm
4	0.1 mm
5	0.02 mm
6	0.002 mm
8	0.001 mm

f Continued on next page

*/ Non standard stroke lengths are available; must be encoded in 5 mm / 0.1 in. increments

9/ Encode in meters if using metric stroke length. Encode in feet if using US customary stroke length

f		Output (continued)
Filtering performance (box no. 20)		
8		Noise reduction filter (8 measurements)
G		Noise reduction filter (8 measurements) + error delay (10 cycles)
Signal options (box no. 21, 22)		
0	0	Measuring direction forward, asynchronous mode
0	1	Measuring direction reverse, asynchronous mode
0	2	Measuring direction forward, synchronous mode 1
0	5	Measuring direction forward, asynchronous mode, bit 25 = alarm, bit 26 = parity even
9	9	Write "9" in box no. 21 and 22 for using further combinations in boxes 23, 24, 25.
Measurement contents (optional: box no. 23)		
Note: Choose "9" in box no. 21 and 22.		
1		Position measurement
Direction and sync. mode (optional: box no. 24)		
Note: Choose "9" in box no. 21 and 22.		
1		Measuring direction forward, asynchronous mode
2		Measuring direction forward, synchronous mode 1
5		Measuring direction reverse, asynchronous mode
6		Measuring direction reverse, synchronous mode 1
Diagnostics (optional: box no. 25)		
Note: Choose "9" in box no. 21 and 22.		
0		No further options
2		Additional alarm bit + parity even bit

3.5 Order code of Temposonics® RF

1	2	3	4	5	6	7	8	9	10	11	12	13	14	15	16	17	18	19	20	21	22	23	
R	F											1	S										
a		b	c						d			e	f										

21, 22, 23: Optional

a	Sensor model	
R	F	Flexible sensor rod

b	Design
C	Base unit
M	Threaded flange M18×1.5-6g
S	Threaded flange ¾"-16 UNF-3A

c	Stroke length					
X	X	X	X	X	M	00150...20,000 mm
X	X	X	X	X	U	0006.0...0787.0 in.

Standard stroke length (mm)*

Stroke length	Ordering steps
150 ... 1000 mm	50 mm
1000 ... 5000 mm	100 mm
5000 ... 10,000 mm	250 mm
10,000...15,000 mm	500 mm
> 15,000 mm	1000 mm

Standard stroke length (in.)*

Stroke length	Ordering steps
6 ... 40 in.	2 in.
40...197 in.	4 in.
197...394 in.	10 in.
394...591 in.	20 in.
> 591 in.	40 in.

d	Connection type		
D	7	0	M16 (7 pin) male connector See "Frequently ordered accessories" for cable connector specifications
F	X	X	XX m PUR cable (part no. 530 045) F01...F10 (1...10 m / 3...33 ft.) ¹⁰ See "Frequently ordered accessories" for cable specifications
H	X	X	XX m PUR cable (part no. 530 052) H01...H10 (1...10 m / 3...33 ft.) ¹⁰ See "Frequently ordered accessories" for cable specifications
M	S	0	MS0 (10 pin) male connector
P	X	X	XX m TPU cable (part no. 530 029) P01...P10 (1...10 m / 3...33 ft.) ¹⁰ See "Frequently ordered accessories" for cable specifications
R	X	X	XX m PVC cable (part no. 530 032) R01...R10 (1...10 m / 3...33 ft.) ¹⁰ See "Frequently ordered accessories" for cable specifications

e	Operating voltage
1	+24 VDC (-15 / +20 %)

f Continued on next page

*/ Non standard stroke lengths are available; must be encoded in 5 mm / 0.1 in. increments

¹⁰/Encode in meters if using metric stroke length. Encode in feet if using US customary stroke length

f	Output
S (15) (16) (17) (18) (19) (20) (21) (22) (23) = Synchronous Serial Interface	
Data length (box no. 15)	
1	25 bit
2	24 bit
3	26 bit
Output format (box no. 16)	
B	Binary
G	Gray
Resolution (box no. 17)	
1	0.005 mm
2	0.01 mm
3	0.05 mm
4	0.1 mm
5	0.02 mm
6	0.002 mm
Filtering performance (box no. 18)	
A	No filter + error delay (4 cycles)
C	No filter + error delay (8 cycles)
1	Standard (no filters)
8	Noise reduction filter (8 measurements)
D	No filter + error delay (10 cycles)
G	Noise reduction filter (8 measurements) + error delay (10 cycles)
K	Peak reduction filter (8 measurements)
N	Peak reduction filter (8 measurements) + error delay (10 cycles)
Signal options (box no. 19, 20)	
0 0	Measuring direction forward, asynchronous mode
0 1	Measuring direction reverse, asynchronous mode
0 2	Measuring direction forward, synchronous mode 1
0 5	Measuring direction forward, asynchronous mode, bit 25 = alarm, bit 26 = parity even
9 9	Write "9" in box no. 19 and 20 for using further combinations in boxes 21, 22, 23 .

f	Output (continued)
Measurement contents (optional: box no. 21) Note: Choose "9" in box no. 19 and 20.	
1	Position measurement
2	Differentiation measurement ¹¹
3	Velocity measurement
4	Position measurement + temperature measurement (only with data length = 24 bit)
5	Differentiation measurement ¹¹ + temperature measurement (only with data length = 24 bit)
6	Velocity measurement + temperature measurement (only with data length = 24 bit)
Direction and sync. mode (optional: box no. 22) Note: Choose "9" in box no. 19 and 20.	
1	Measuring direction forward, asynchronous mode
2	Measuring direction forward, synchronous mode 1
3	Measuring direction forward, synchronous mode 2
4	Measuring direction forward, synchronous mode 3
5	Measuring direction reverse, asynchronous mode
6	Measuring direction reverse, synchronous mode 1
7	Measuring direction reverse, synchronous mode 2
8	Measuring direction reverse, synchronous mode 3
Diagnostics (optional: box no. 23) Note: Choose "9" in box no. 19 and 20.	
0	No further options
2	Additional alarm bit + parity even bit (not available for temperature output, only with data length = 24 bit)

11/You need a second magnet for differentiation measurement

3.6 Nameplate

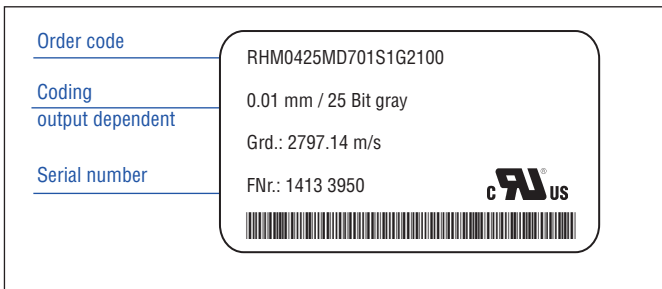


Fig. 1: Example of a nameplate of a RH sensor (production site Germany)

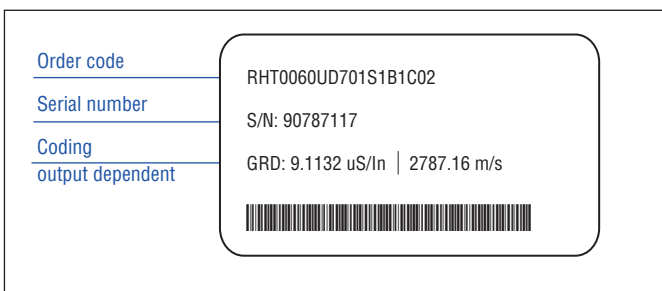


Fig. 2: Example of a nameplate of a RH sensor (production site USA)

3.7 Approvals

CE certified (RP / RH / RF), UL approved (RP / RH),
GOST certified (RP / RH / RD4 / RF)

3.8 Scope of delivery

RP (profile sensor):

- Sensor, position magnet
- 2 mounting clamps up to 1250 mm (50 in.) stroke length +
1 mounting clamp for each 500 mm (20 in.) additional stroke length

RH (rod sensor):

- RH-B: Base unit, 2 socket screws M4
- RH-D / -H / -J / -M / -R / -S / -T / -U / -V: Sensor, O-ring

RD4 (detached sensor electronics):

- RD4-C / -D / -G / -M / -T: Sensor, O-ring
- RD4-S: Sensor, O-ring, back-up ring

RT4 (redundant with detached electronics):

- Sensor, O-ring

RF (flexible sensor rod):

- RF-C: Base unit
- RF-M / -S: Sensor, O-ring

4. Product description and commissioning

4.1 Functionality and system design

Product designation

- Position sensor Temposonics® R-Series

Sensor model

- Temposonics® RP (profile sensor)
- Temposonics® RH (rod sensor)
- Temposonics® RD4 (detached sensor electronics)
- Temposonics® RT4 (redundant with detached sensor electronics)
- Temposonics® RF (flexible sensor rod)

Stroke length

- RP 25... 5080 mm (1.0...200.0 in.)
- RH 25... 7620 mm (1.0...300.0 in.)
- RD4 25... 5080 mm (1.0...200.0 in.)
- RT4 25... 2540 mm (1.0...100.0 in.)
- RF 150...20,000 mm (6.0...787.0 in.)

Output signal

- SSI

Application

Temposonics® position sensors are used for measurement and conversion of the length (position) variable in the fields of automated systems and mechanical engineering.

Principle of operation and system construction

The absolute, linear position sensors provided by Temposonics rely on the company's proprietary Temposonics® magnetostrictive technology, which can determine position with a high level of precision and robustness. Each Temposonics® position sensor consists of a ferromagnetic waveguide, a position magnet, a strain pulse converter and supporting electronics. The magnet, connected to the object in motion in the application, generates a magnetic field at its location on the waveguide. A short current pulse is applied to the waveguide. This creates a momentary radial magnetic field and torsional strain on the waveguide. The momentary interaction of the magnetic fields releases a torsional strain pulse that propagates the length of the waveguide. When the ultrasonic wave reaches the end of the waveguide it is converted into an electrical signal. Since the speed of the ultrasonic wave in the waveguide is precisely known, the time required to receive the return signal can be converted into a linear position measurement with both high accuracy and repeatability.

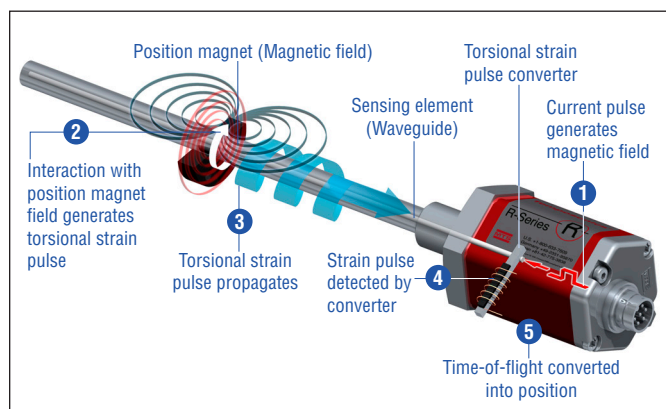


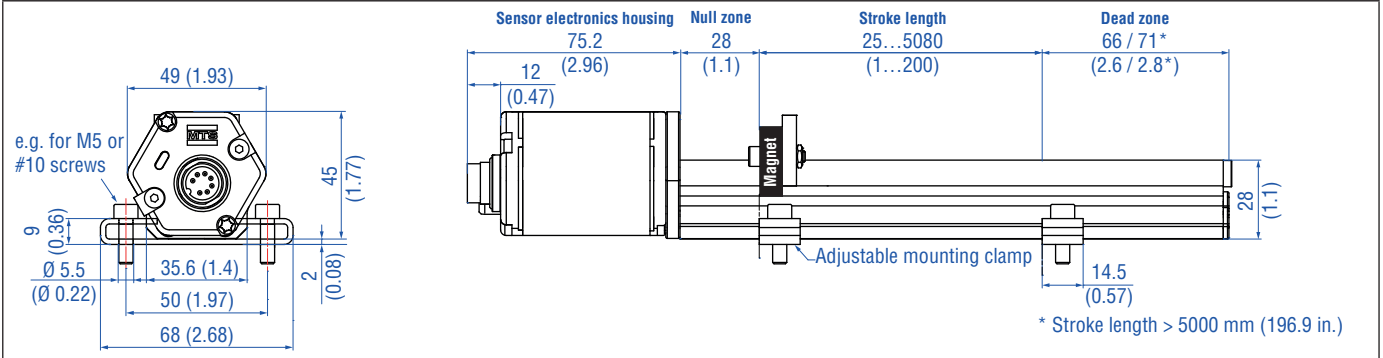
Fig. 3: Time-of-flight based magnetostrictive position sensing principle

Modular mechanical and electronic construction

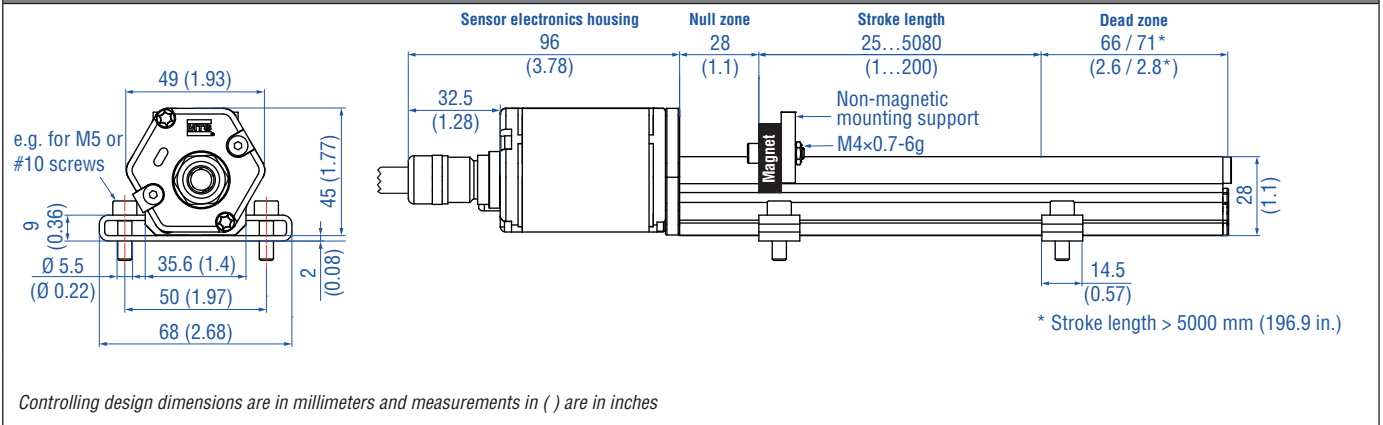
- The sensor rod or profile protects the inner sensor element.
- The sensor electronics housing, a rugged aluminum construction, contains the complete electronic interface with active signal conditioning. Double shielding ensures high safety of operation and optimum EMC (Electromagnetic Compatibility).
- The external position magnet is a permanent magnet. Mounted on the mobile machine part, it travels along the sensor rod or profile and triggers the measurement through the sensor rod wall.
- The sensor can be connected directly to a control system. Its electronics generates a strictly position proportional signal output between start and end position.

4.2 Styles and installation of Temposonics® RP

RP-M, example: Connector outlet D70



RP-M, example: Cable outlet FXX / HXX / PXX / RXX



Controlling design dimensions are in millimeters and measurements in () are in inches

Fig. 4: Temposonics® RP with U-magnet

Installation of RP

The position sensor can be installed in any position. Normally, the sensor is firmly installed and the position magnet is fastened to the mobile machine part. Thus it can travel along the sensor profile. The sensor is fitted on a flat machine surface using the mounting clamps (Fig. 5). A length-dependent number of these clamps is delivered with the sensor and must be distributed over the profile at regular distances. For fastening use M5×20 screws to DIN 6912 that should be tightened with a fastening torque of 5 Nm.

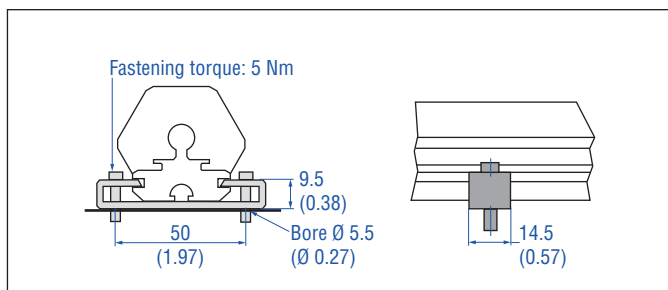


Fig. 5: Mounting clamps (part no. 400 802) with cylinder screw M5×20

Alternative: If only limited space is available, the profile sensor can be mounted also via the T-rail in the profile bottom using an T-slot nut M5 (part no. 401 602) or a sliding block (Fig. 6).

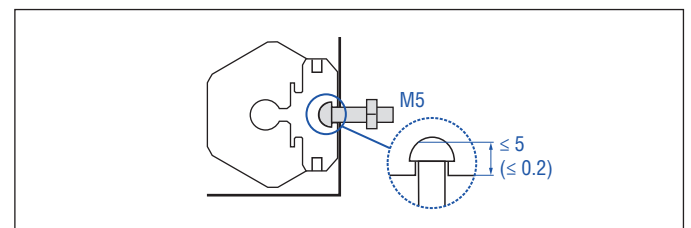


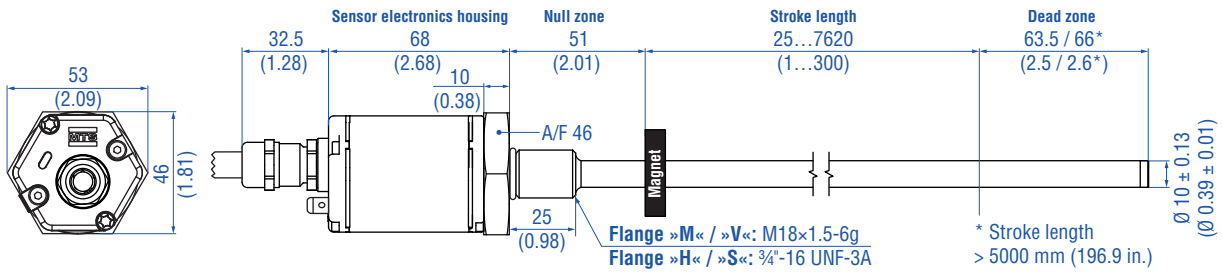
Fig. 6: T-slot nut M5 (part no. 401 602)

NOTICE Take care to mount the sensor in an axially parallel position to avoid damage to magnet and sensor.

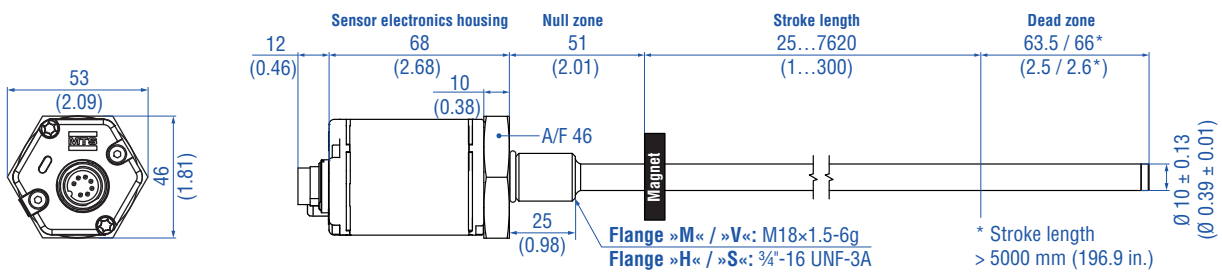
Controlling design dimensions are in millimeters and measurements in () are in inches

4.3 Styles and installation of Temposonics® RH

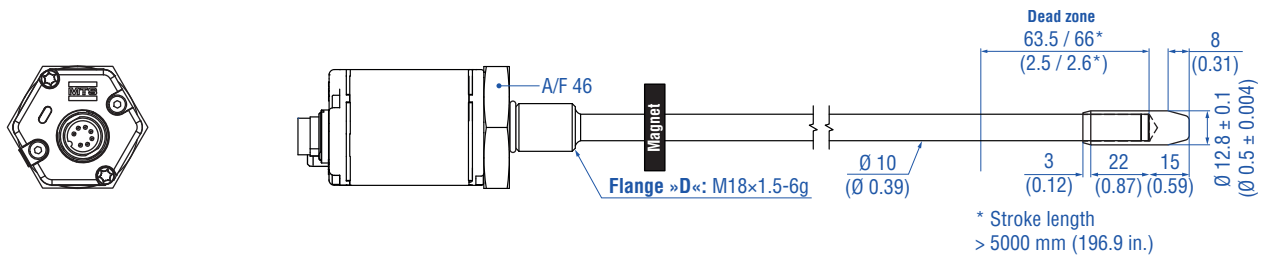
RH-H / -M / -S / -V, example: Cable outlet FXX / HXX / PXX / RXX



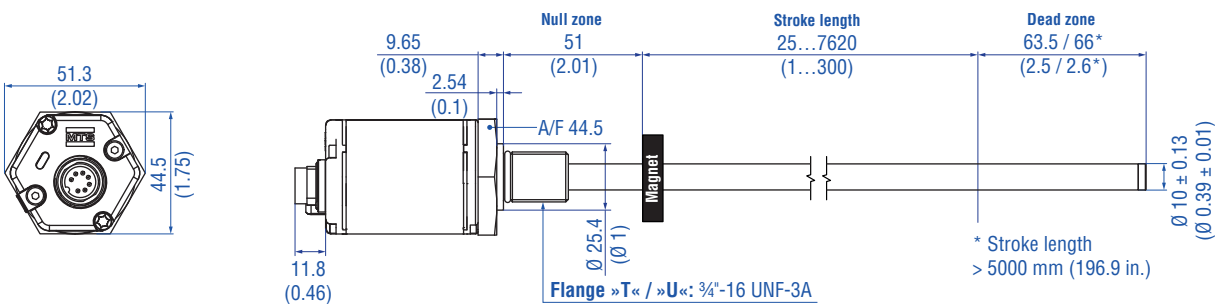
RH-H / -M / -S / -V, example: Connector outlet D70



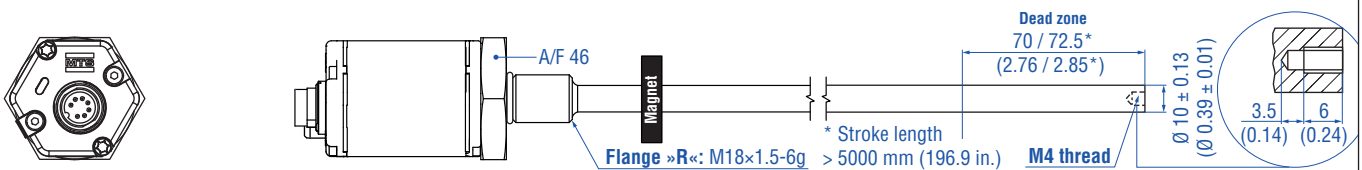
RH-D, example: Connector outlet D70



RH-T / -U, example: Connector outlet D70



RH-R, example: Connector outlet D70



Controlling design dimensions are in millimeters and measurements in () are in inches

Fig. 7: Temposonics® RH with ring magnet part 1

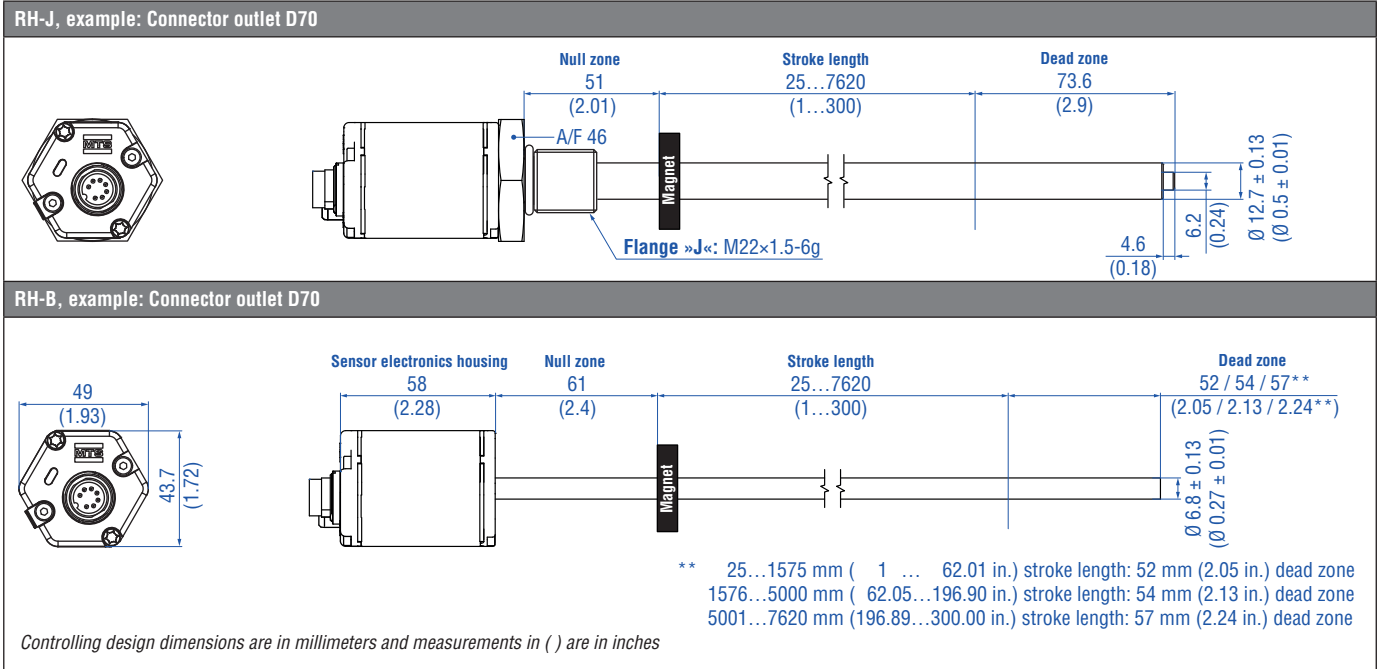


Fig. 8: Temposonics® RH with ring magnet part 2

Installation of RH with threaded flange »D«, »H«, »J«, »M«, »S«, »T«, »U«, »V« & »R«

Fix the sensor rod via threaded flange M18×1.5-6g, M22×1.5-6g or 3/4"-16 UNF-3A.

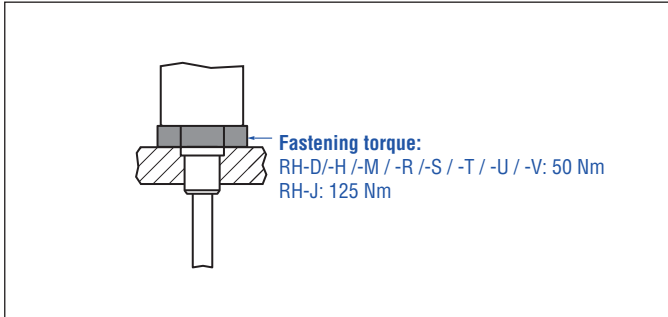


Fig. 9: Mounting example of threaded flange »D«, »H«, »J«, »M«, »S«, »T«, »U«, »V«, »R«

Installation of a rod-style sensor in a fluid cylinder

The rod-style version has been developed for direct stroke measurement in a fluid cylinder. Mount the sensor via threaded flange or a hex nut.

- Mounted on the face of the piston, the position magnet travels over the rod without touching it and indicates the exact position through the rod wall – independent of the hydraulic fluid.
- The pressure resistant sensor rod is installed into a bore in the piston rod.
- The base unit is mounted by means of only two screws. It is the only part that needs to be replaced if servicing is required, i.e. the hydraulic circuit remains closed. For more information see chapter "4.8 Replacement of sensor" on page 37.

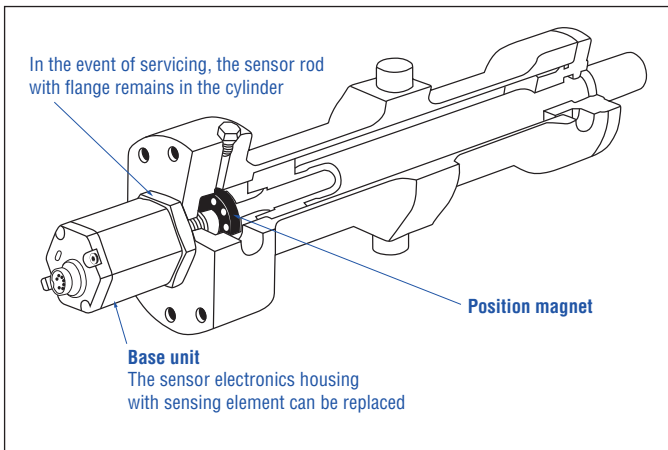


Fig. 10: Sensor in cylinder

Hydraulics sealing

There are two ways to seal the flange contact surface (Fig. 11):

1. A sealing by using an O-ring (e.g. 22.4 × 2.65 mm (0.88 × 0.1 in.), 25.07 × 2.62 mm (0.99 × 0.1 in.)) in a cylinder bottom groove.
2. A sealing by using an O-ring in the undercut.

For threaded flange (3/4"-16 UNF-3A) »H« / »S« / »T« / »U«:

O-ring 16.4 × 2.2 mm (0.65 × 0.09 in.) (part no. 560 315)

For threaded flange (M18×1.5-6g) »D« / »M« / »R« / »V«:

O-ring 15.3 × 2.2 mm (0.60 × 0.09 in.) (part no. 401 133)

For threaded flange (M22×1.5-6g) »J«:

O-ring 19.2 × 2.2 mm (0.76 × 0.09 in.) (part no. 561 337)

In the case of threaded flange M18×1.5-6g or M22×1.5-6g, provide a screw hole based on ISO 6149-1 (Fig. 12). See ISO 6149-1 for further information.

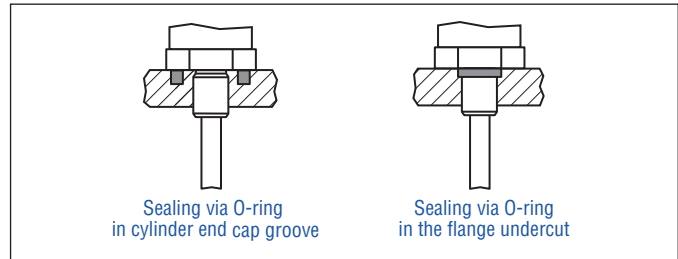


Fig. 11: Possibilities of sealing

- Note the fastening torque of:
RH-D/-H /-M /-R /-S /-T /-U /-V: 50 Nm
RH-J: 125 Nm
- Seat the flange contact surface completely on the cylinder mounting surface.
- The cylinder manufacturer determines the pressure-resistant gasket (copper gasket, O-ring, etc.).
- The position magnet should not grind on the sensor rod.
- The piston rod drilling
(RH-H /-M /-R /-S /-T /-U /-V: Ø 10 mm rod: ≥ Ø 13 mm (≥ Ø 0.51 in.);
RH-D: Ø 10 mm rod: ≥ Ø 16 mm (≥ Ø 0.63 in.);
RH-J: Ø 12.7 mm rod: ≥ Ø 16 mm (≥ Ø 0.63 in.)) depends on the pressure and piston speed.
- Adhere to the information relating to operating pressure.
- Protect the sensor rod against wear.

Notice for metric threaded flanges

Thread (d ₁ ×P)	d ₂	d ₃	d ₄	d ₅ +0.1 0	L ₁ +0.4 0	L ₂	L ₃	L ₄	Z° ±1°
RH-M / -R / -V									
M18×1.5-6g	55	≥ 13	24.5	19.8	2.4	28.5	2	26	15°
RH-D									
M18×1.5-6g	55	≥ 16	24.5	19.8	2.4	28.5	2	26	15°
RH-J									
M22×1.5-6g	55	≥ 16	27.5	23.8	2.4	28.5	2	26	15°

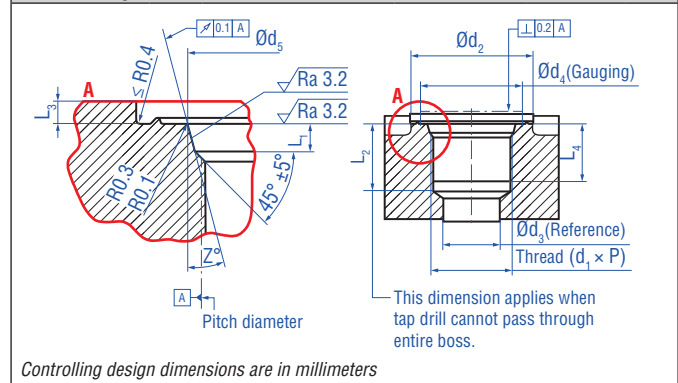


Fig. 12: Notice for metric threaded flange M18×1.5-6g / M22×1.5-6g based on DIN ISO 6149-1

4.4 Styles and installation of Temposonics® RD4

Sensor electronics housing

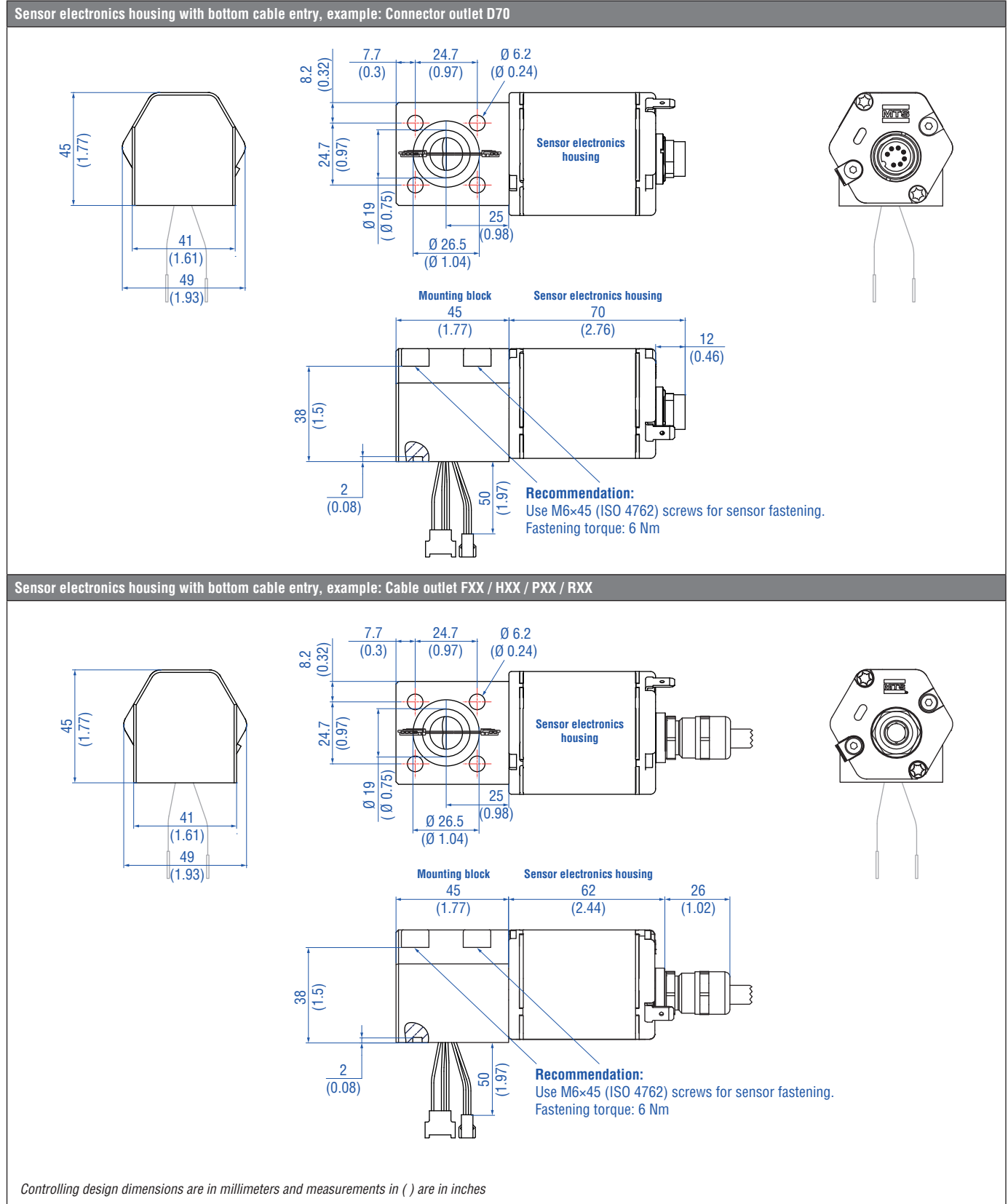


Fig. 13: Temposonics® RD4 sensor electronics housing with bottom cable entry

Sensor electronics housing

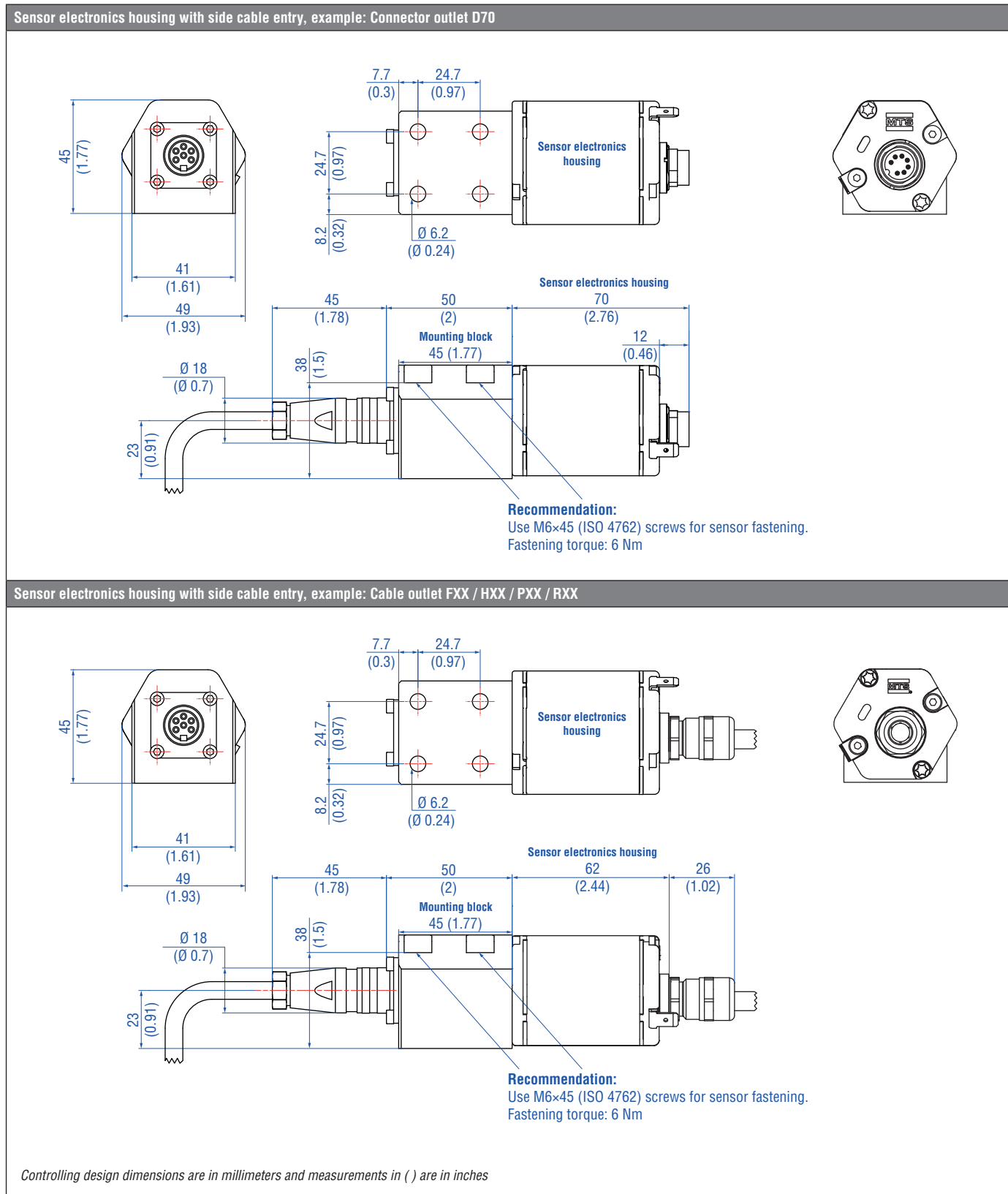


Fig. 14: Temposonics® RD4 sensor electronics housing with side cable entry

Flanges

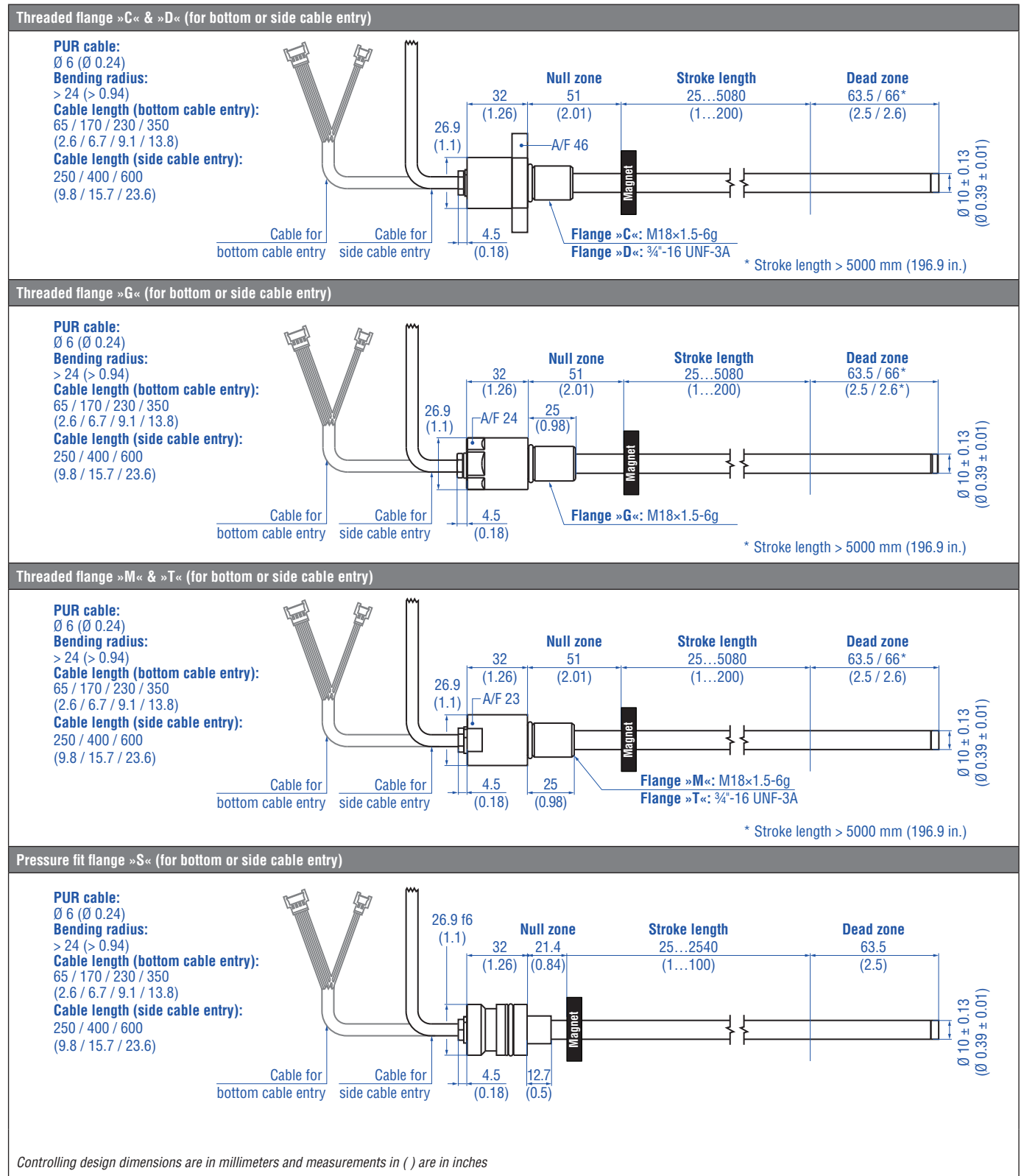
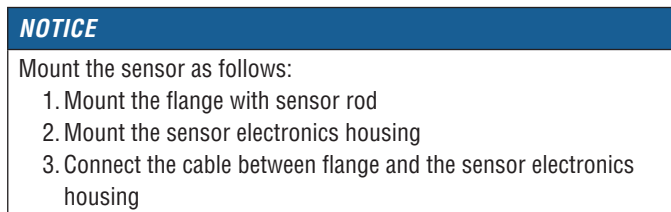
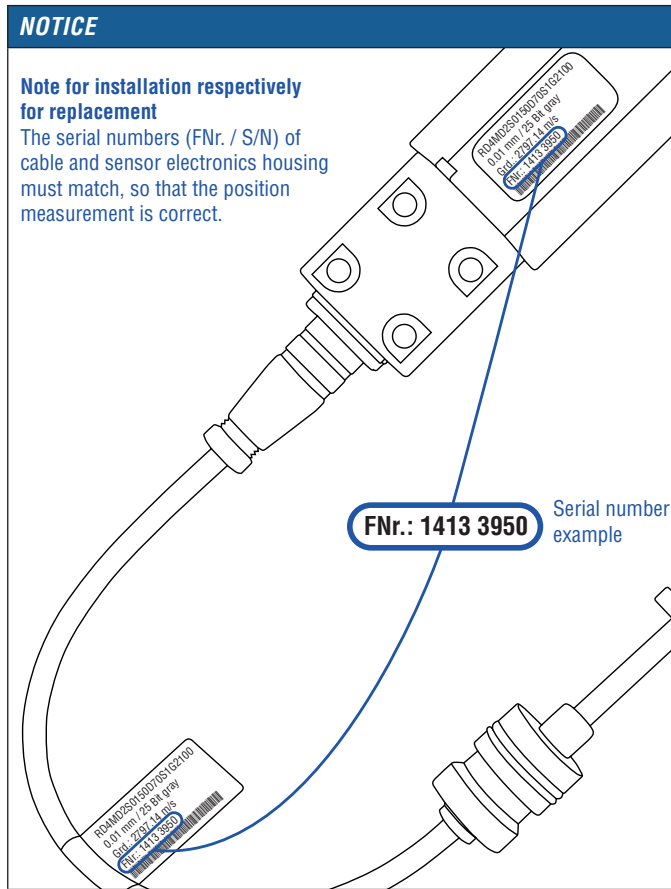


Fig. 15: Temposonics® RD4 flanges with ring magnet



The steps mentioned above will be explained in chapter 4.4.1, chapter 4.4.2 and chapter 4.4.3.

4.4.1 Installation of RD4 with threaded flange

Fix the sensor rod via threaded flange M18×1.5-6g or ¾"-16 UNF-3A.

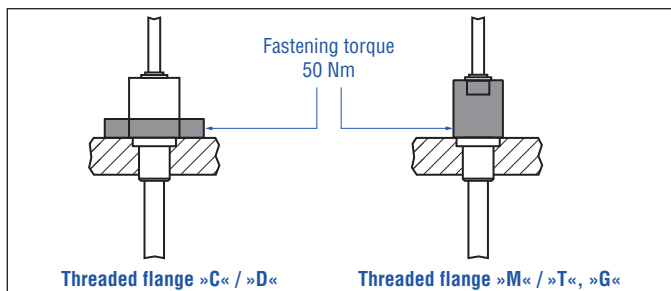


Fig. 16: Mounting example of threaded flange »C« / »D«, »M« / »T« & »G«

Installation of a rod-style sensor in a fluid cylinder

The rod-style version has been developed for direct stroke measurement in a fluid cylinder. Mount the sensor via threaded flange or a hex nut.

- Mounted on the face of the piston, the position magnet travels over the rod without touching it and indicates the exact position through the rod wall – independent of the hydraulic fluid.
- The pressure resistant sensor rod is installed into a bore in the piston rod.

Hydraulics sealing

There are the following ways to seal the flange contact surface (Fig. 17):

For threaded flange »C« / »D«:

1. A sealing by using an O-ring (e.g. 22.4 × 2.65 mm (0.88 × 0.1 in.), 25.07 × 2.62 mm (0.99 × 0.1 in.)) in a cylinder end cap groove.

For threaded flange (¾"-16 UNF-3A) »D« / »T«:

2. A sealing by using an O-ring 16.4 × 2.2 mm (0.65 × 0.09 in.) (part no. 560 315) in the undercut.

For threaded flange (M18×1.5-6g) »C« / »M« & »G«:

3. A sealing by using an O-ring 15.3 × 2.2 mm (0.6 × 0.09 in.) (part no. 401 133) in the undercut. In this case, a screw hole based on ISO 6149-1 (Fig. 18) must be provided. See ISO 6149-1 for further information.

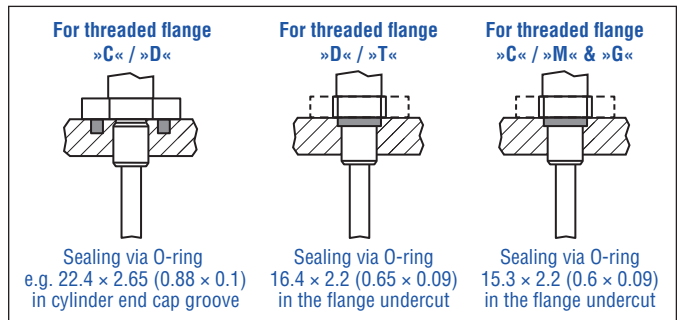


Fig. 17: Possibilities of sealing

- Note the fastening torque of 50 Nm.
- Seat the flange contact surface completely on the cylinder mounting surface.
- The cylinder manufacturer determines the pressure-resistant gasket (copper gasket, O-ring, etc.).
- The position magnet should not grind on the sensor rod.
- The piston rod drilling ($\geq \text{Ø } 13 \text{ mm}$ ($\geq \text{Ø } 0.51 \text{ in.}$)) depends on the pressure and piston speed.
- Adhere to the information relating to operating pressure.
- Protect the sensor rod against wear.

Notice for metric threaded flanges

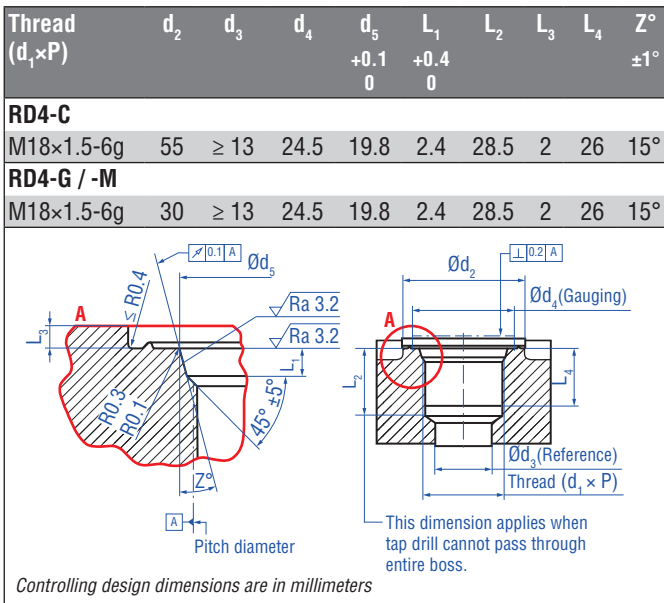


Fig. 18: Notice for metric threaded flange M18×1.5-6g based on DIN ISO 6149-1

4.4.2 Installation of RD4 with pressure fit flange

Cylinder mounting

Install the rod using the pressure fit flange. Seal it off by means of the O-ring and the back-up ring. Block the pressure fit flange using a shoulder screw (Fig. 19). For details of the pressure fit flange »S« see Fig. 20. Also note the mounting examples in Fig. 21 and Fig. 22.

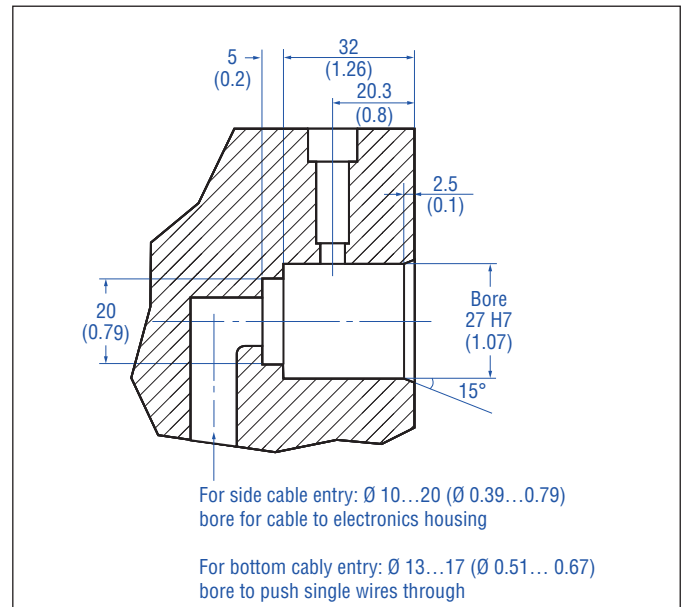


Fig. 19: Example of mounting detail: Shoulder screw 8-M6 (ISO 7379) with internal hexagon

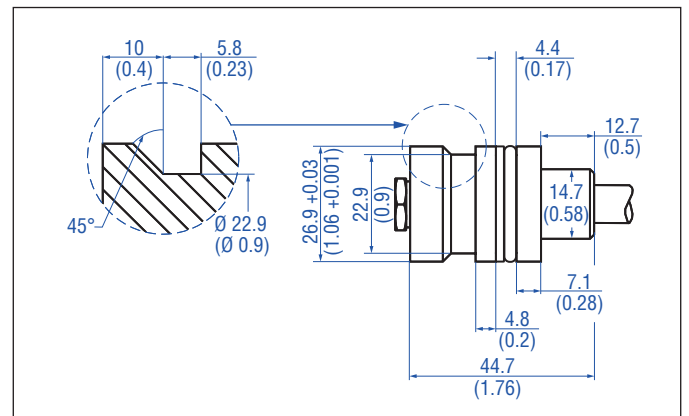


Fig. 20: Pressure fit flange »S« details

Note for cylinder installation:

- The position magnet should not grind on the sensor rod.
- The piston rod drilling ($\geq \text{Ø } 13 \text{ mm}$ ($\geq \text{Ø } 0.51 \text{ in.}$)) depends on the pressure and piston speed.
- Adhere to the information relating to operating pressure.
- Protect the sensor rod against wear.

4.4.3 Installation of RD4's sensor electronics housing

The following section explains the connection of a RD4 sensor with bottom cable entry (Fig. 21) and side cable entry (Fig. 22) based on RD4-S. The sensor electronics of RD4 sensors with threaded flange are mounted in the same way.

Sensor electronics with bottom cable entry

Connect the rod via the connector to the sensor electronics. Mount the sensor electronics so that you can lead the cables below the bottom of the housing. Thus the sensor system including the connection cables is fully encapsulated and protected against external disturbances (Fig. 21). Note the bending radius of the cable if you run the cable between sensor electronics and rod (see Fig. 15).

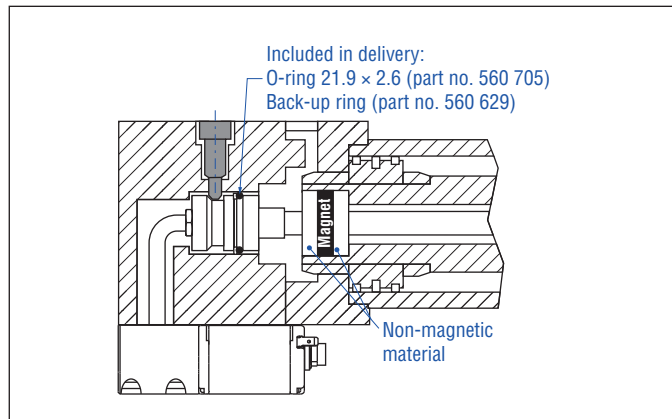


Fig. 21: Mounting example of pressure fit flange »S« and sensor electronics with bottom cable entry

Sensor electronics with side cable entry

Connect the rod via the cable to the sensor electronics on the side. Encapsulate the sensor system including the connection cables (Fig. 22). Note the bending radius of the cable if you run the cable between sensor electronics and rod (see Fig. 15).

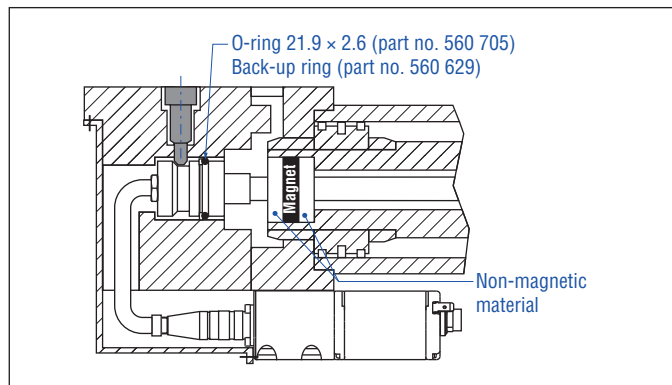


Fig. 22: Mounting example of pressure fit flange »S« and sensor electronics with side cable entry

NOTICE

To fulfill the EMC standards for emission and immunity the following points are necessary:

- The sensor electronics housing has to be connected to machine ground.
- The cable between the sensor and the electronics must be integrated into a metallic housing.

Connect the flange to the sensor electronics housing via the molex connectors for bottom cable entry respectively via the 6 pin cable for side cable entry.

Mounting of sensor electronics housing

Mount the sensor electronics housing with 4 M6x45 (ISO 4762) screws via the mounting block. Note the fastening torque of 6 Nm.

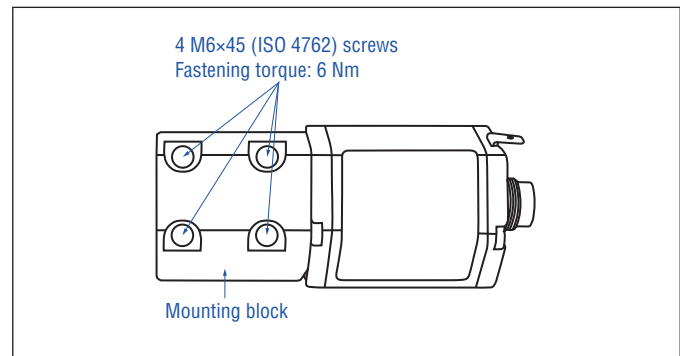


Fig. 23: Mounting of RD4's sensor electronics housing (example of bottom cable entry)

4.5 Styles and installation of Temposonics® RT4

Sensor electronics housing

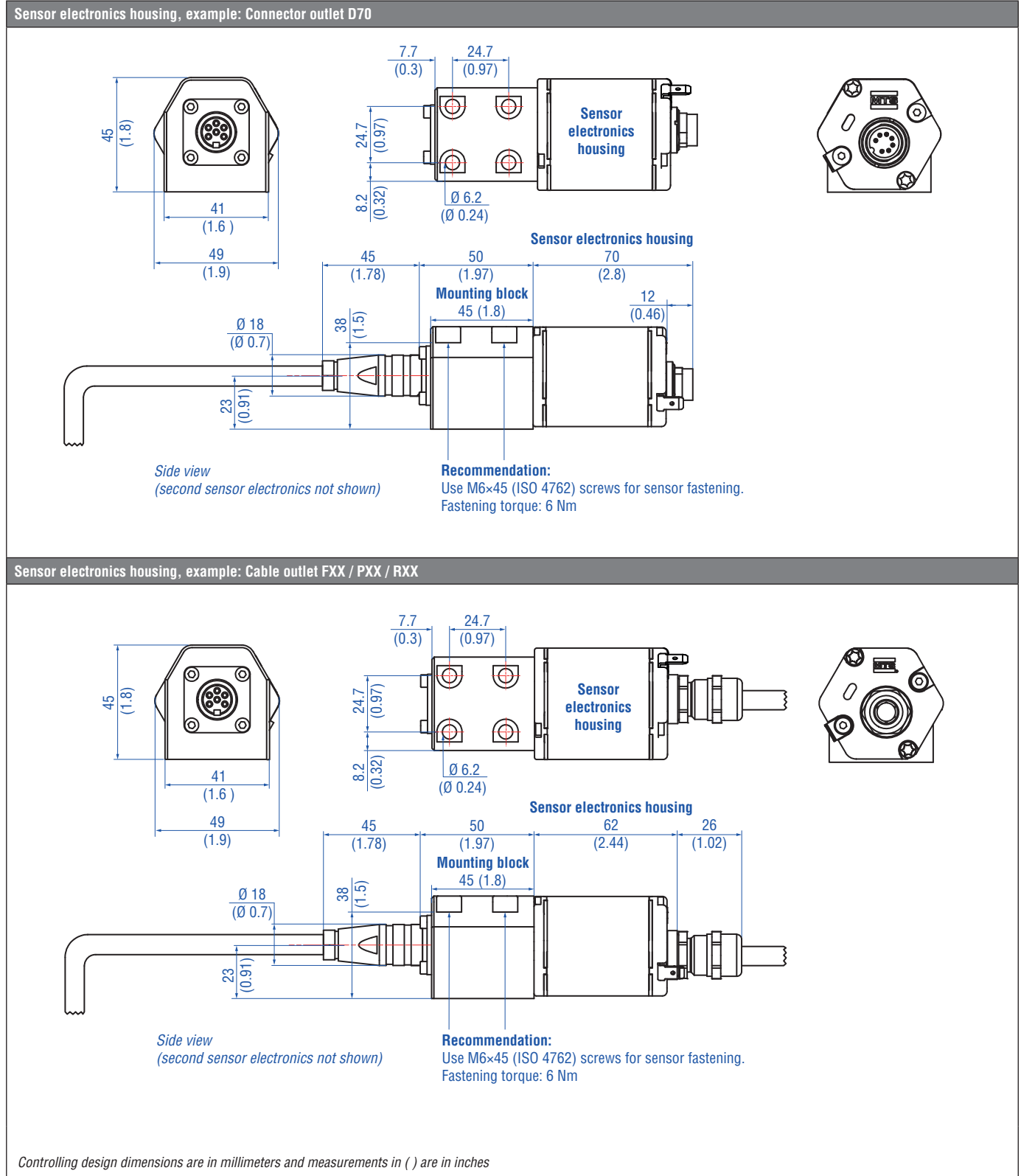


Fig. 24: Temposonics® RT4 sensor electronics housing

Flanges

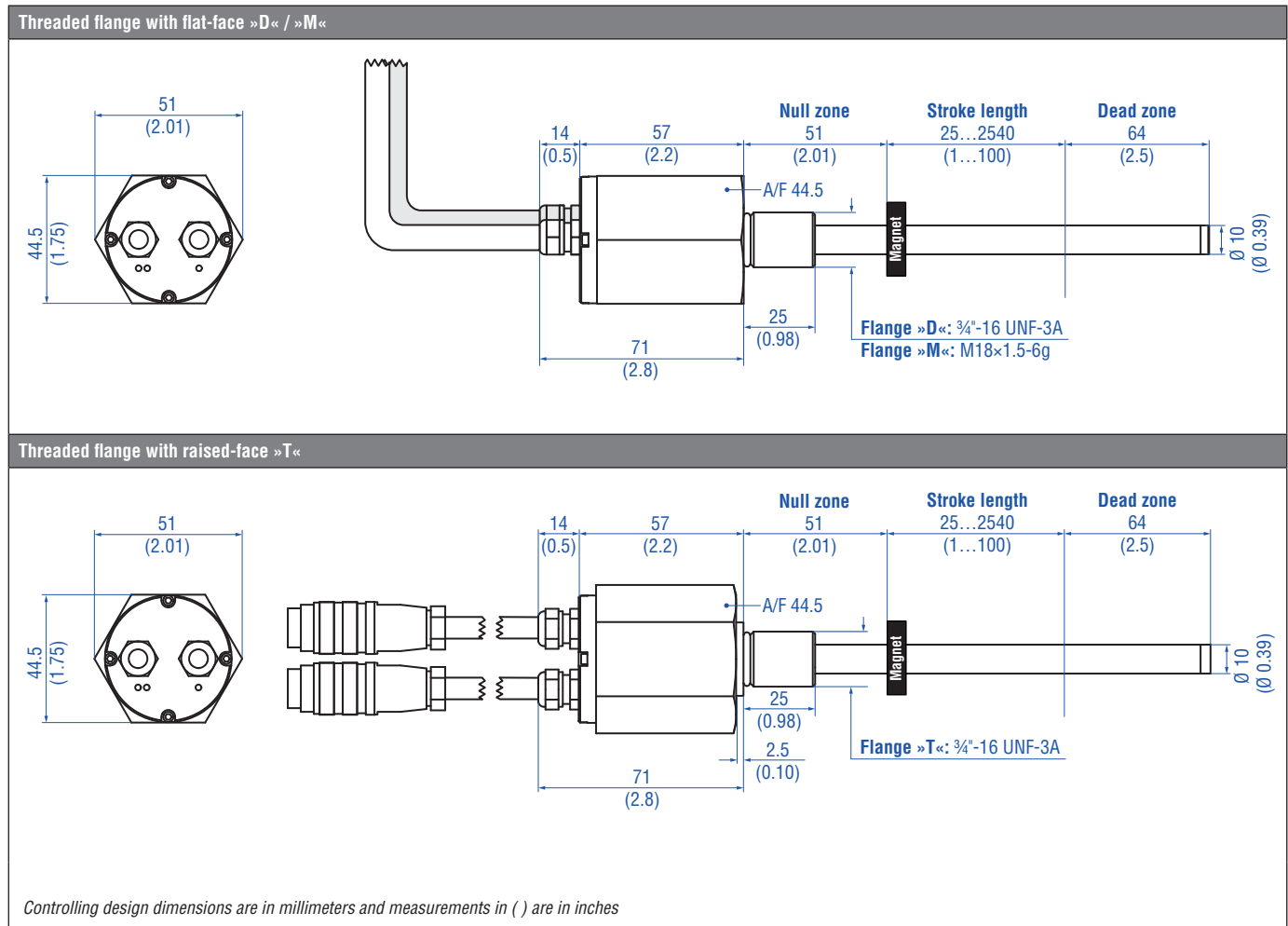
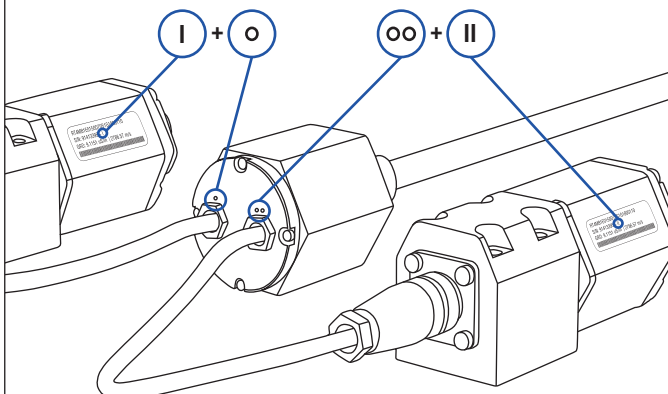


Fig. 25: Temposonics® RT4 flanges with ring magnet

NOTICE

Note for installation respectively for replacement

The position measurement is erroneous, if the sensor will not be connected as shown!



NOTICE

Mount the sensor as follows:

1. Mount the flange with sensor rod
2. Mount the sensor electronics housing
3. Connect the cable between flange and the sensor electronics housing

The steps mentioned above will be explained in chapter 4.5.1 and chapter 4.5.2.

4.5.1 Installation of RT4 with threaded flange

Fix the sensor rod via threaded flange M18×1.5-6g or ¾"-16 UNF-3A.

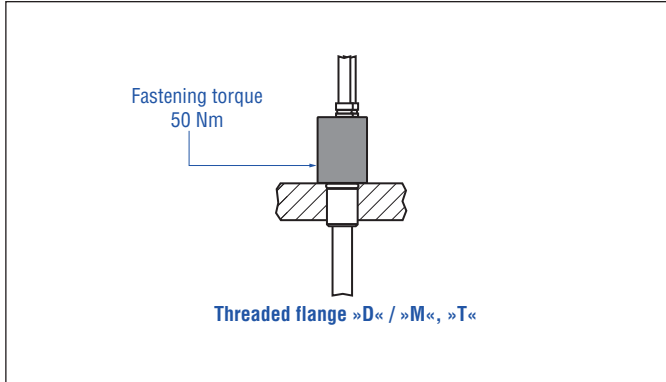


Fig. 26: Mounting example of threaded flange »D« / »M« & »T«

Installation of a rod-style sensor in a fluid cylinder

The rod-style version has been developed for direct stroke measurement in a fluid cylinder. Mount the sensor via threaded flange or a hex nut.

- Mounted on the face of the piston, the position magnet travels over the rod without touching it and indicates the exact position through the rod wall – independent of the hydraulic fluid.
- The pressure resistant sensor rod is installed into a bore in the piston rod.

Hydraulics sealing

There are two ways to seal the flange contact surface (Fig. 27):

1. A sealing by using an O-ring (e.g. 22.4 × 2.65 mm (0.88 × 0.1 in.), 25.07 × 2.62 mm (0.99 × 0.1 in.)) in a cylinder end cap groove.
2. A sealing by using an O-ring in the undercut.

For threaded flange (¾"-16 UNF-3A) »D« / »T«:

O-ring 16.4 × 2.2 mm (0.65 × 0.09 in.) (part no. 560 315)

For threaded flange (M18×1.5-6g) »M«:

O-ring 15.3 × 2.2 mm (0.60 × 0.09 in.) (part no. 401 133)

In this case, a screw hole based on ISO 6149-1 must be provided (Fig. 28). See ISO 6149-1 for further information.

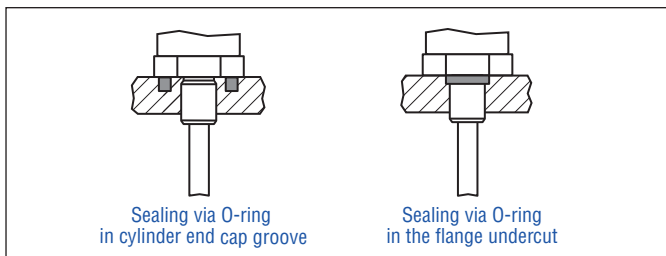


Fig. 27: Possibilities of sealing

- Note the fastening torque of 50 Nm.
- Seat the flange contact surface completely on the cylinder mounting surface.
- The cylinder manufacturer determines the pressure-resistant gasket (copper gasket, O-ring, etc.).
- The position magnet should not grind on the sensor rod.
- The piston rod drilling ($\geq \varnothing 13 \text{ mm}$ ($\geq \varnothing 0.51 \text{ in.}$)) depends on the pressure and piston speed.
- Adhere to the information relating to operating pressure.
- Protect the sensor rod against wear.

Notice for metric threaded flanges

Thread ($d_1 \times P$)	d_2	d_3	d_4	d_5 +0.1 0	L_1 +0.4 0	L_2	L_3	L_4	Z° $\pm 1^\circ$
RT4-M									
M18×1.5-6g	55	13	24.5	19.8	2.4	28.5	2	26	15°

Fig. 28: Notice for metric threaded flange M18×1.5-6g based on DIN ISO 6149-1

4.5.2 Installation of RT4's sensor electronics housing

Connect the rod via the cable to the sensor electronics on the side. Encapsulate the sensor system including the connection cables (Fig. 29).

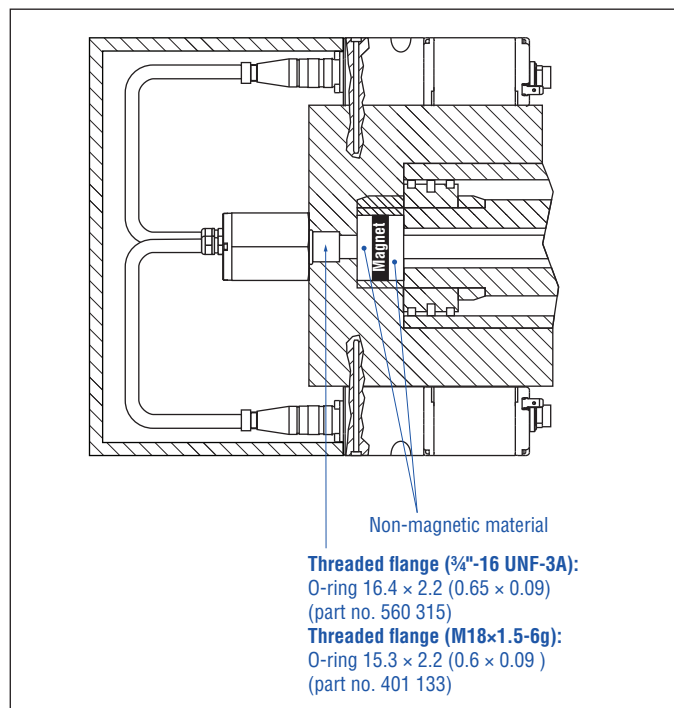


Fig. 29: Mounting example of RT4

Mounting of sensor electronics housing

Mount the sensor electronics housing with 4 M6×45 (ISO 4762) screws via the mounting block. Note the fastening torque of 6 Nm.

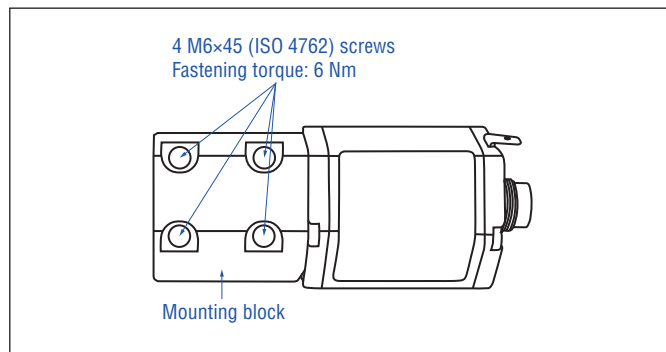


Fig. 30: Mounting of RT4's sensor electronics housing

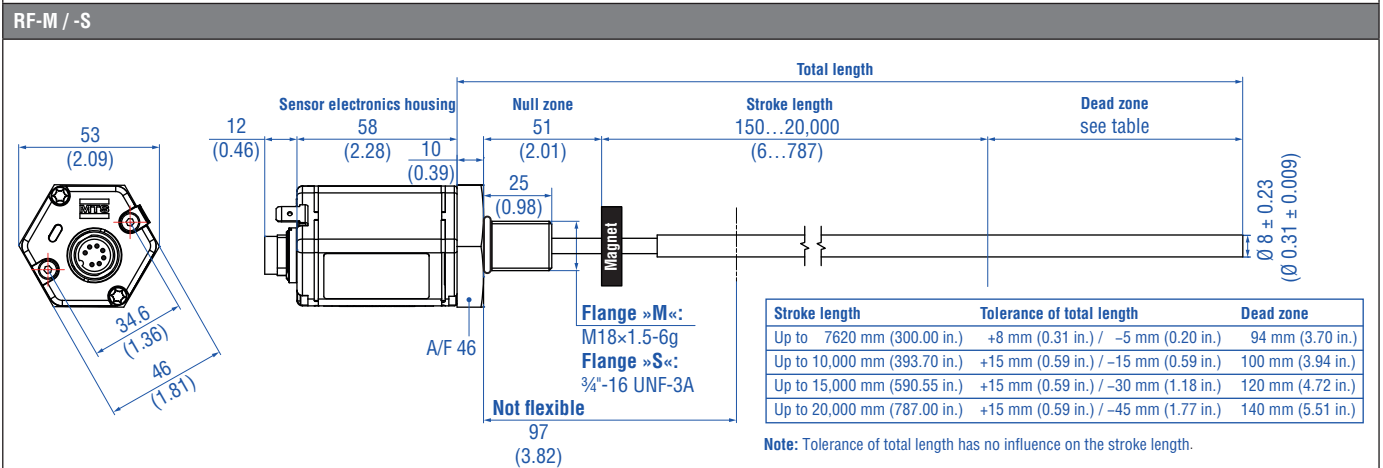
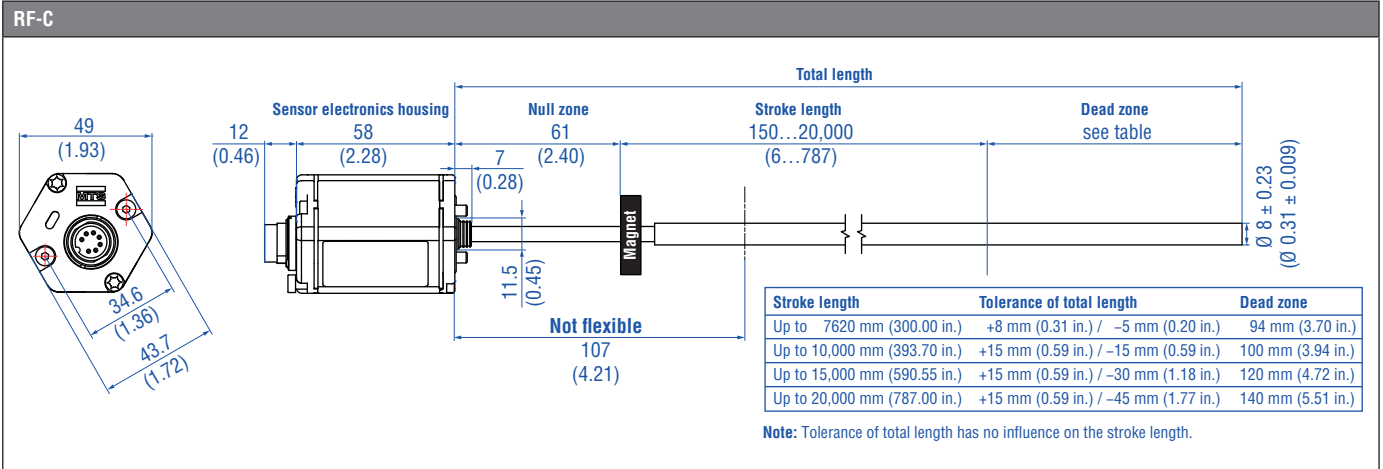
NOTICE

To fulfill the EMC standards for emission and immunity the following points are necessary:

- The sensor electronics housing has to be connected to machine ground.
- The cable between the sensor and the electronics must be integrated into a metallic housing.

Connect the flange to the sensor electronics housing via the 6 pin cable.

4.6 Styles and installation of Temposonics® RF



Controlling design dimensions are in millimeters and measurements in () are in inches

Fig. 31: Temposonics® RF base unit with ring magnet (top) RF with threaded flange with ring magnet (bottom)

Note the following information when mounting a RF sensor:

1. Always insert the flexible sensor rod in a support tube (e.g. pressure rod HD / HL / HP or HFP profile). The support tube with an inside diameter of 9.4 mm (0.37 in.) consists of non-magnetic material. The support tube can be straight or bent (note the bending radius in Fig. 33).

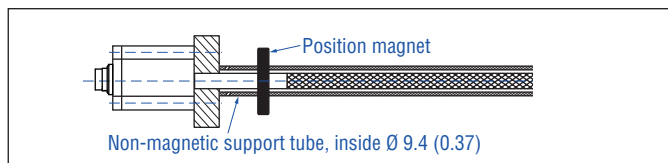


Fig. 32: Sensor with support tube

2. Do never bend beyond the minimum bending radius of 250 mm (9.84 in.)
3. Note the minimum distance to a spatial limitation of 300 mm (11.81 in.), when mounting / dismantling the sensor (Fig. 33).
4. Note that the first 107 mm (4.21 in.) (for RF-C) respectively 97 mm (3.82 in.) (for RF-M) of the sensor rod are not flexible.

NOTICE
Smaller radiuses cause damage to the flexible sensor rod.

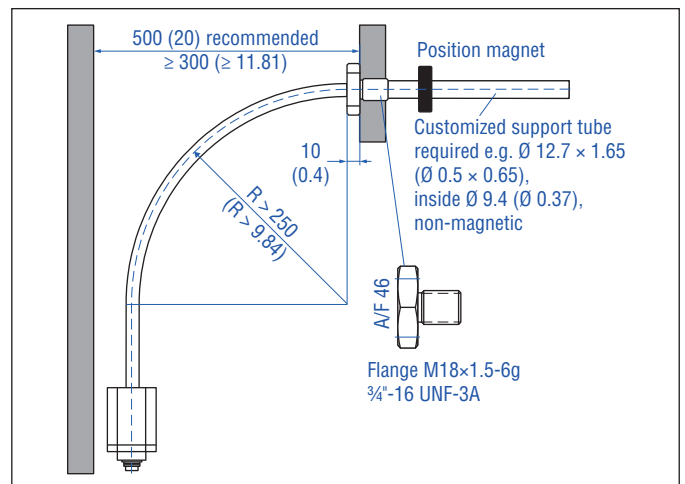


Fig. 33: Clearances for installation

Controlling design dimensions are in millimeters and measurements in () are in inches

This is the way you mount the RF sensors:

Sensor design	Mounting
RF-C	<ul style="list-style-type: none"> Insert the flexible sensor rod in a support tube. Mount the sensor electronics housing by means of 2 non-magnetic socket head screws M4×59. Fastening torque: 2 Nm (see Fig. 34) <p><u>Recommendation:</u> Seal the sensor via flange.</p>
RF-C with pressure rod HD / HL / HP or HFP profile (see “Frequently ordered accessories”)	<p><u>Advantage:</u> The flexible sensor rod is inserted in a support tube.</p> <ul style="list-style-type: none"> Mount the sensor electronics housing by means of 2 non-magnetic socket head screws M4×59. Fastening torque: 2 Nm (see Fig. 34)
RF-M / RF-S	<ul style="list-style-type: none"> Insert the flexible sensor rod in a support tube. Mount the sensor via flange.

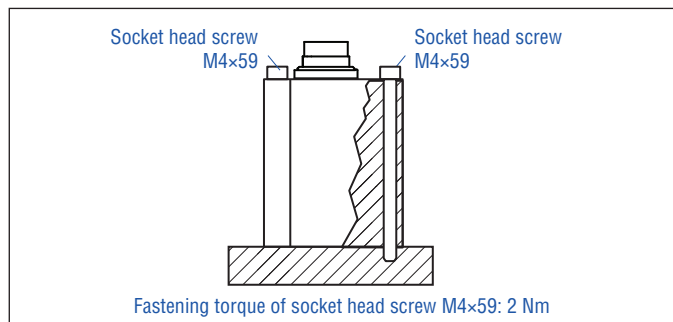


Fig. 34: Mounting with socket head screws M4×59

NOTICE
Connect the sensor electronics housing to machine ground to fulfill the EMC standards for emission and immunity.

Installation of RF with threaded flange »M«, »S« or RF with pressure rod HD / HL / HP

Fix the sensor rod via threaded flange M18×1.5-6g or ¾"-16 UNF-3A.

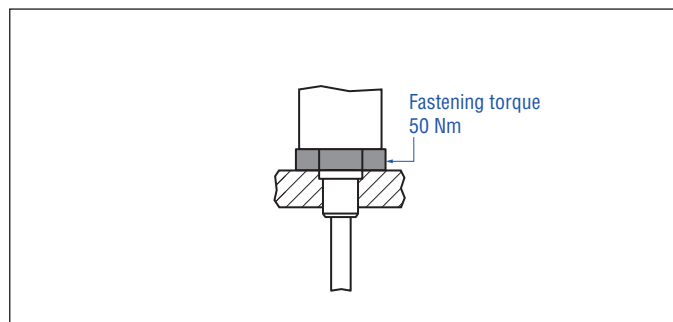


Fig. 35: Mounting example of threaded flange »M«, »S« or pressure rod HD / HL / HP

Installation of a RF sensor with pressure rod HD / HL / HP in a fluid cylinder

The rod-style version has been developed for direct stroke measurement in a fluid cylinder. Mount the sensor via threaded flange or a hex nut.

- Mounted on the face of the piston, the position magnet travels over the rod without touching it and indicates the exact position through the rod wall – independent of the hydraulic fluid.
- The pressure resistant sensor rod is installed into a bore in the piston rod.
- The base unit is mounted by means of only 2 screws. It is the only part that needs to be replaced if servicing is required, i.e. the hydraulic circuit remains closed. For more information see chapter “4.8 Replacement of sensor” on page 37.

Hydraulics sealing when using a RF sensor in a pressure rod HD / HL / HP

There are two ways to seal the flange contact surface (Fig. 36):

- A sealing by using an O-ring (e.g. 22.4 × 2.65 mm (0.88 × 0.1 in.), 25.07 × 2.62 mm (0.99 × 0.1 in.)) in a cylinder end cap groove.
- A sealing by using an O-ring in the undercut.

For threaded flange (¾"-16 UNF-3A) »S«:

O-ring 16.4 × 2.2 mm (0.65 × 0.09 in.) (part no. 560 315)

For threaded flange (M18×1.5-6g) »M«:

O-ring 15.3 × 2.2 mm (0.60 × 0.09 in.) (part no. 401 133)

In this case, a screw hole based on ISO 6149-1 must be provided (Fig. 37). See ISO 6149-1 for further information.

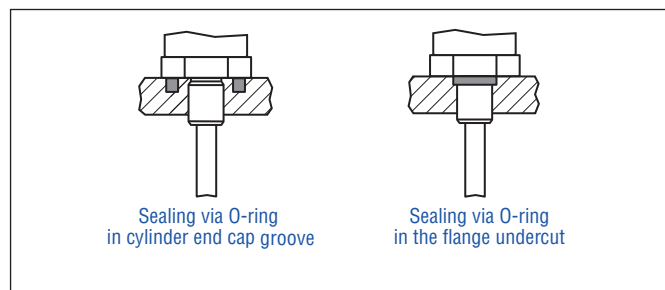


Fig. 36: Possibilities of sealing

Note the following points when using a RF-M / -S sensor respectively pressure rod HD / HL / HP:

- Note the fastening torque of 50 Nm.
- Seat the flange contact surface completely on the cylinder mounting surface.
- The cylinder manufacturer determines the pressure-resistant gasket (copper gasket, O-ring, etc.).
- The position magnet should not grind on the sensor rod.
- The piston rod drilling for RF sensors with pressure rod (outer diameter 12.7 mm (0.5 in.)) is ≥ 16 mm (≥ 0.63 in.). The borehole depends on the pressure and piston speed.
- Adhere to the information relating to operating pressure.
- Protect the sensor rod against wear.

Notice for metric threaded flanges

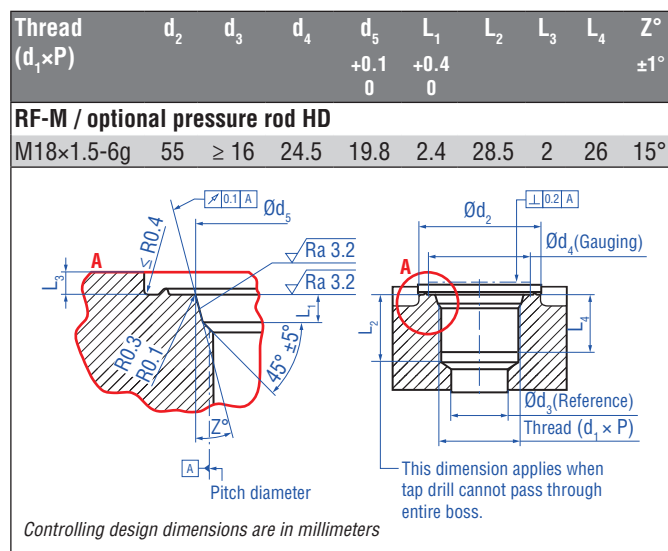


Fig. 37: Notice for metric threaded flange M18x1.5-6g based on DIN ISO 6149-1

For additional information about optional accessories see:

- HFP profile (document part number: 551442)
- Pressure rod HD / HL / HP (document part number: 551770)

4.7 Magnet installation

Typical use of magnets




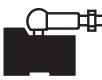
Magnet	Typical sensors	Benefits
 Ring magnets	Rod models (RH, RD4, RT4, RF)	<ul style="list-style-type: none"> • Rotationally symmetrical magnetic field
 U-magnets	Profile & rod models (RP, RH, RD4, RT4, RF)	<ul style="list-style-type: none"> • Height tolerances can be compensated
 Block magnets	Profile & rod models (RP, RH, RF)	<ul style="list-style-type: none"> • The magnet can be lifted off • Height tolerances can be compensated
 Magnet sliders	Profile models (RP)	<ul style="list-style-type: none"> • The magnet is guided through the profile • The distance between the magnet and the waveguide is strictly defined • Easy coupling via the ball joint

Fig. 38: Typical use of magnets

Mounting ring magnets, U-magnets & block magnets

Install the magnet using non-magnetic material for mounting device, screws, spacers etc.. The magnet must not grind on the sensor rod. Alignment errors are compensated via the air gap.

- Permissible surface pressure: Max. 40 N/mm² (only for ring magnets and U-magnets)
- Fastening torque for M4 screws: 1 Nm; use washers, if necessary
- Minimum distance between position magnet and any magnetic material has to be 15 mm (0.6 in.) (Fig. 41).
- If no other option exists and magnetic material is used, observe the specified dimensions (Fig. 41).

NOTICE

Mount ring magnets and U-magnets concentrically.
Mount block magnets centrally over the sensor rod or the sensor profile.
Do not exceed the maximum acceptable gap (Fig. 39 / Fig. 40).

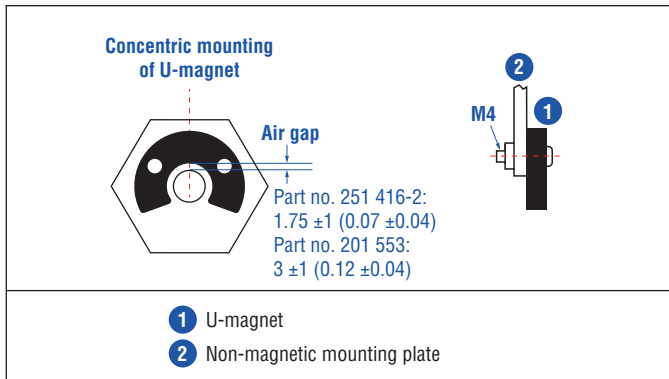


Fig. 39: Mounting of U-magnet (part no. 251 416-2 or part no. 201 553)

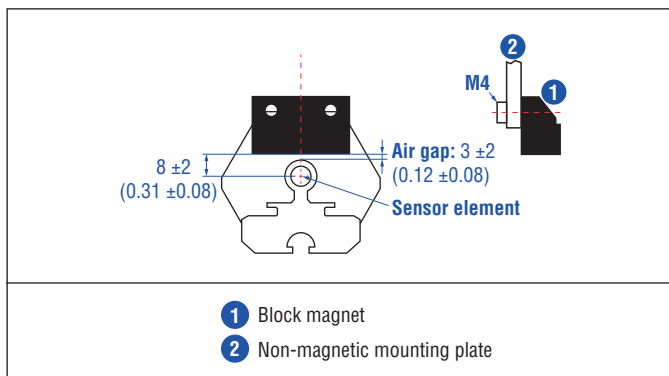


Fig. 40: Mounting of block magnet (part no. 403 448)

Magnet mounting with magnetic material

When using magnetic material the dimensions of Fig. 41 must be observed.

- A.** If the position magnet aligns with the drilled piston rod
- B.** If the position magnet is set further into the drilled piston rod, install another non-magnetic spacer (e.g. part no. 400 633) above the magnet.

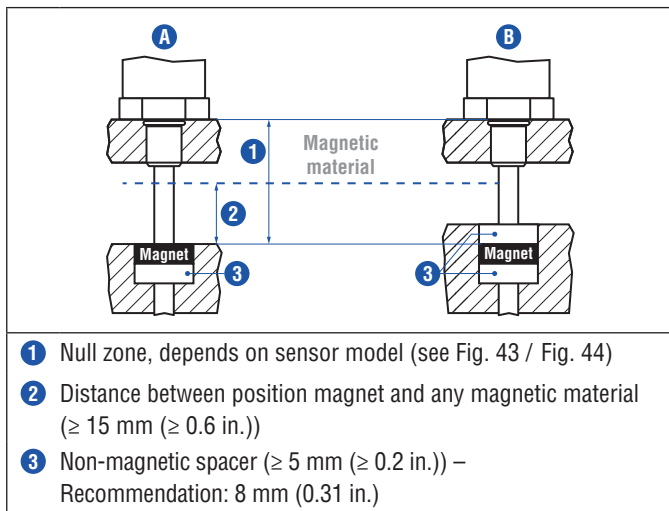


Fig. 41: Installation with magnetic material

Sensors with stroke lengths ≥ 1 meter (3.3 ft.)

Support horizontally installed sensors with a stroke length from 1 meter (3.3 ft.) mechanically at the rod end. Without the use of a support, rod and position magnet may be damaged. A false measurement result is also possible. Longer rods require evenly distributed mechanical support over the entire length (e.g. part no. 561 481). Use an U-magnet (Fig. 42) for measurement.

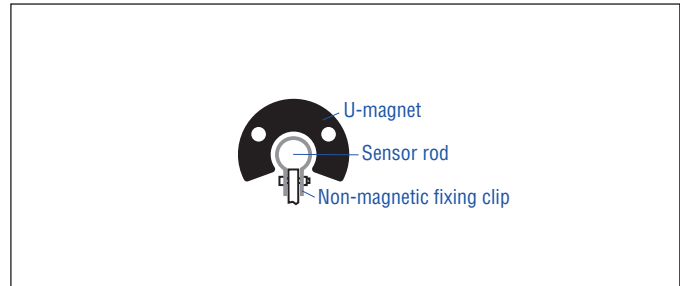


Fig. 42: Example of sensor support (part no. 561 481)

Start- and end positions of the position magnets

Consider the start and end positions of the position magnets during the installation.

To ensure that the entire stroke length is electrically usable, the position magnet must be mechanically mounted as follows.

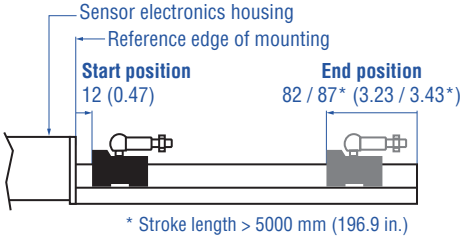
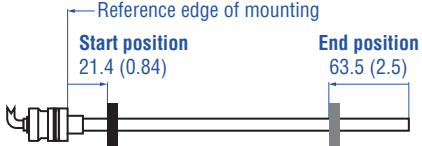
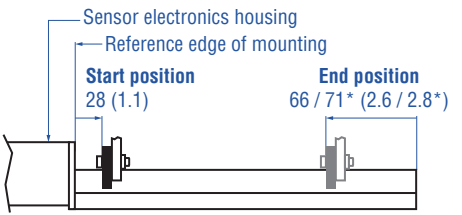
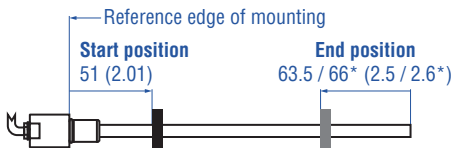
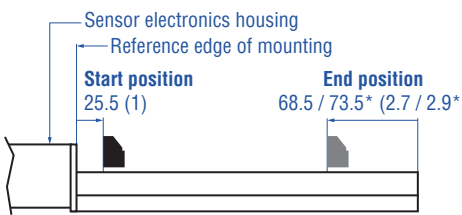
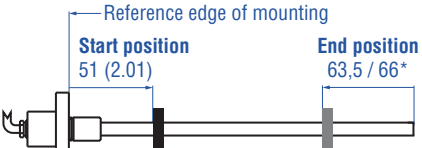
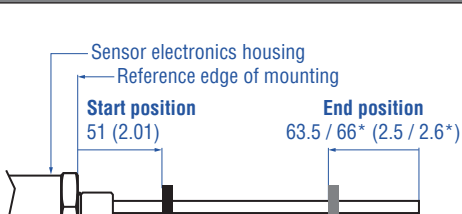
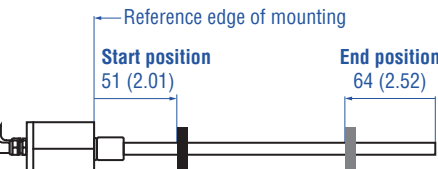
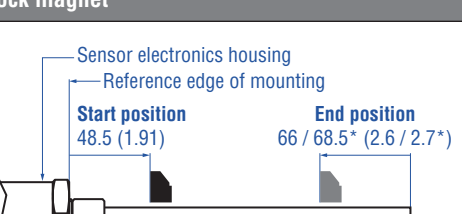
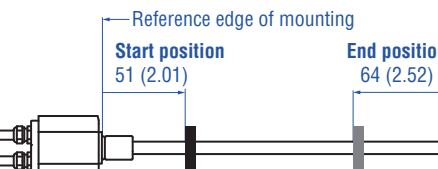
<p>RP with magnet slider “S”, “N”, “V”, “G”</p>  <p>Start position: 12 (0.47) End position: 82 / 87* (3.23 / 3.43*)</p> <p>* Stroke length > 5000 mm (196.9 in.)</p>	<p>RD4-S with ring magnet & U-magnet</p>  <p>Start position: 21.4 (0.84) End position: 63.5 (2.5)</p>
<p>RP with U-magnet</p>  <p>Start position: 28 (1.1) End position: 66 / 71* (2.6 / 2.8*)</p> <p>* Stroke length > 5000 mm (196.9 in.)</p>	<p>RD4-M / -T / -G with ring magnet & U-magnet</p>  <p>Start position: 51 (2.01) End position: 63.5 / 66* (2.5 / 2.6*)</p> <p>* Stroke length > 5000 mm (196.9 in.)</p>
<p>RP with block magnet</p>  <p>Start position: 25.5 (1) End position: 68.5 / 73.5* (2.7 / 2.9*)</p> <p>* Stroke length > 5000 mm (196.9 in.)</p>	<p>RD4-C / -D with ring magnet & U-magnet</p>  <p>Start position: 51 (2.01) End position: 63.5 / 66*</p> <p>* Stroke length > 5000 mm (196.9 in.)</p>
<p>RH with ring magnet & U-magnet</p>  <p>Start position: 51 (2.01) End position: 63.5 / 66* (2.5 / 2.6*)</p> <p>* Stroke length > 5000 mm (196.9 in.)</p>	<p>RT4-D / -M with ring magnet & U-magnet</p>  <p>Start position: 51 (2.01) End position: 64 (2.52)</p>
<p>RH with block magnet</p>  <p>Start position: 48.5 (1.91) End position: 66 / 68.5* (2.6 / 2.7*)</p> <p>* Stroke length > 5000 mm (196.9 in.)</p>	<p>RT4-T with ring magnet & U-magnet</p>  <p>Start position: 51 (2.01) End position: 64 (2.52)</p>

Fig. 43: Start- and end positions of magnets (part 1)

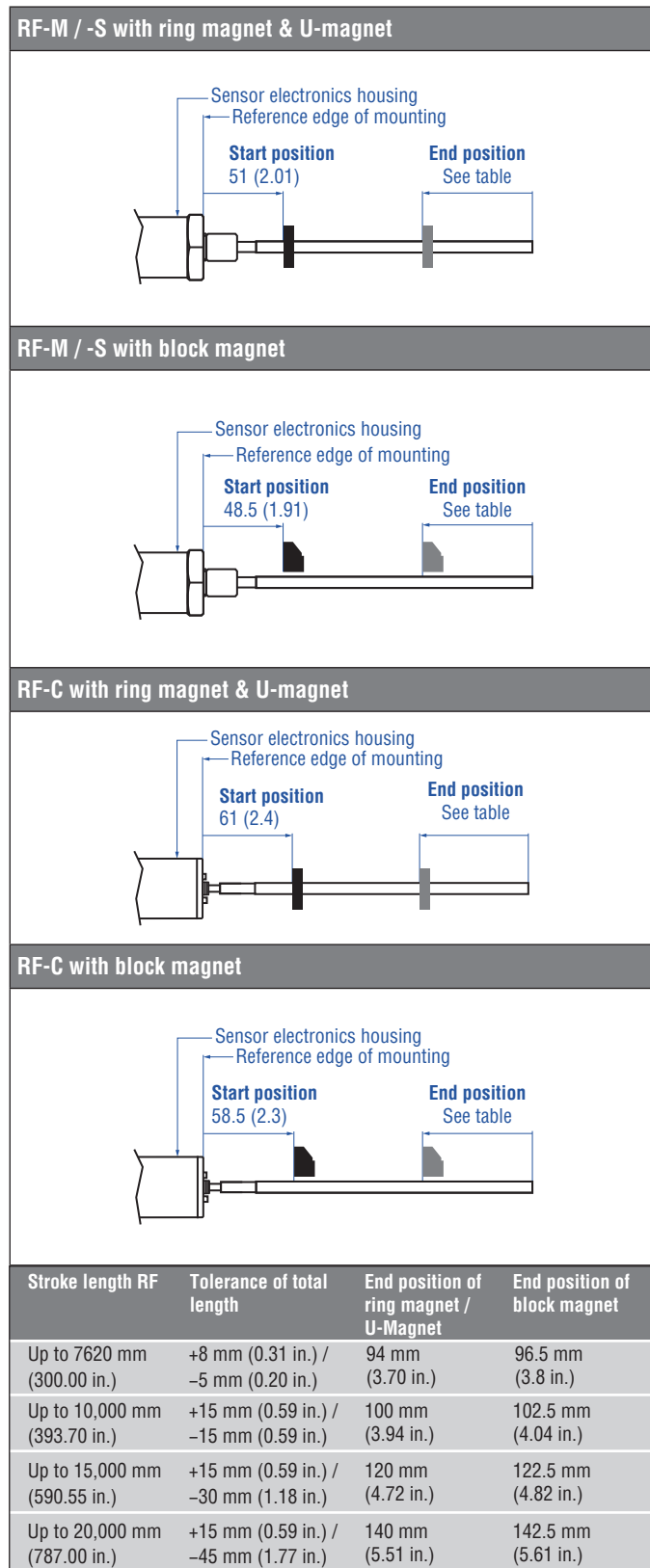


Fig. 44: Start- and end positions of magnets (part 2)

Controlling design dimensions are in millimeters and measurements in () are in inches

NOTICE
On all sensors, the areas left and right of the active stroke length are provided for null and dead zone. These zones should not be used for measurement, however the active stroke length can be exceeded.

Differentiation measurement

For a differentiation measurement two positions are measured on the sensor rod or sensor profile. The distance between these positions will be output.

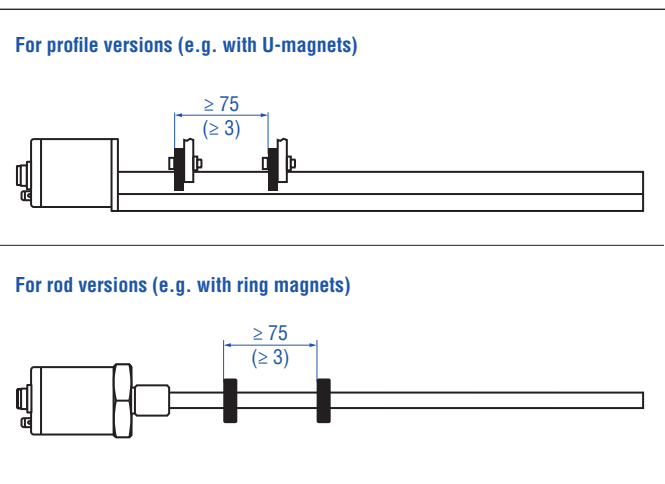


Fig. 45: Minimum distance between magnets for differentiation measurement (RP, RH, RD4, RF), example U-magnets (top) and ring magnets (bottom)

NOTICE
Do not go below a minimal distance of 75 mm (3 in.) between the magnets for differentiation measurement.¹² Use magnets of the same type (e.g. two ring magnets) for differentiation measurement.

¹²Contact Temposonics if you need a magnet distance, which is smaller than 75 mm (3 in.).

4.8 Replacement of sensor

The base unit of the sensor models RH (RH-B) and RF (RF-C) is replaceable as shown in Fig. 46. The sensor can be replaced without interrupting the hydraulic circuit.

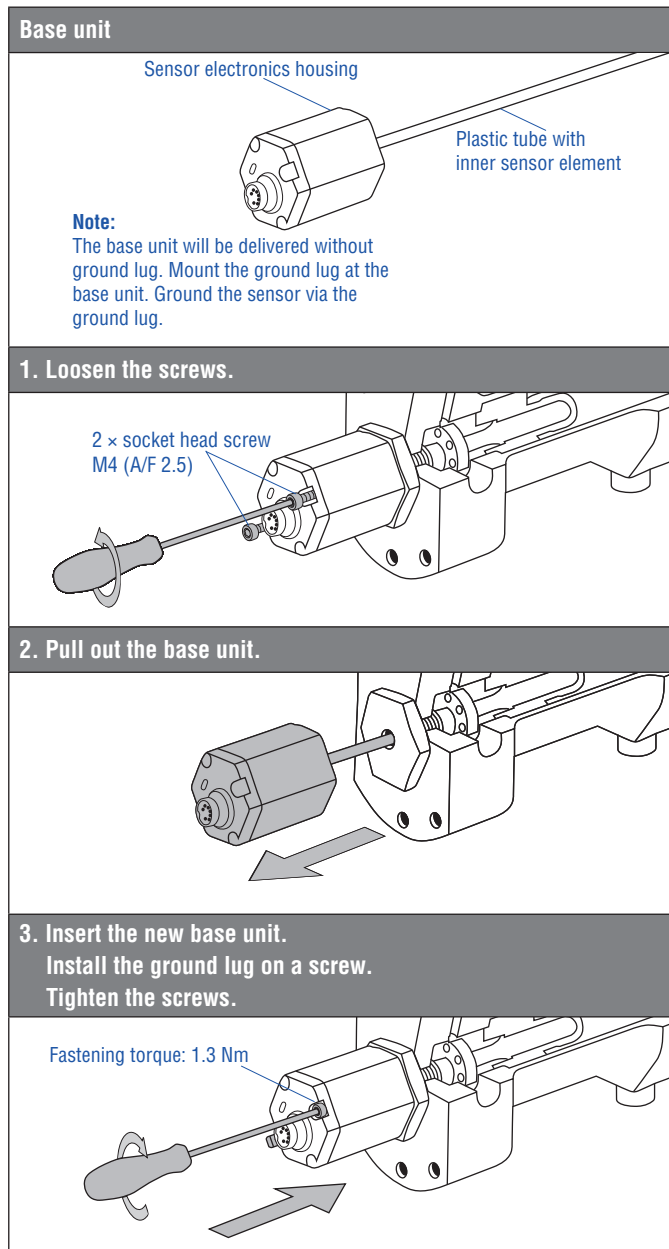


Fig. 46: Replacement of the base unit (e.g. RH sensor)

NOTICE

- The base unit of the high vibration resistant sensor model RH cannot be replaced.
- If necessary, the sensor electronics of sensor model RD4 or RT4 can be replaced. Contact Temposonics for further information.
- Secure the base unit screws, e.g. using Loctite 243, before re-installing.

4.9 Electrical connections

Placement of installation and cabling have decisive influence on the sensor's electromagnetic compatibility (EMC). Hence correct installation of this active electronic system and the EMC of the entire system must be ensured by using suitable metal connectors, shielded cables and grounding. Overvoltages or faulty connections can damage its electronics despite protection against wrong polarity.

NOTICE

1. Do not mount the sensors in the area of strong magnetic or electric noise fields.
2. Never connect / disconnect the sensor when voltage is applied.

Instructions for connection

- Use low-resistance twisted pair and shielded cables. Connect the shield to ground externally via the controller equipment.
- Keep control and signal leads separate from power cables and sufficiently far away from motor cables, frequency inverters, valve lines, relays, etc..
- Use only connectors with metal housing and connect the shielding to the connector housing.
- Keep the connection surface at both shielding ends as large as possible. Connect the cable clamps to function as a ground.
- Keep all non-shielded leads as short as possible.
- Keep the earth connection as short as possible with a large cross section. Avoid ground loops.
- With potential differences between machine and electronics earth connections, no compensating currents are allowed to flow across the cable shielding.

Recommendation:

Install potential compensating leads with large cross section, or use cables with separate double shielding, and connect only one end of the shield.

- Use only stabilized power supplies in compliance with the specified connecting values.

Grounding of profile and rod sensors

Connect the sensor electronics housing to machine ground. Ground sensor types RP, RH, RD4, RT4 and RF via ground lug as shown in Fig. 47. In addition you can ground the sensor type RH via thread.

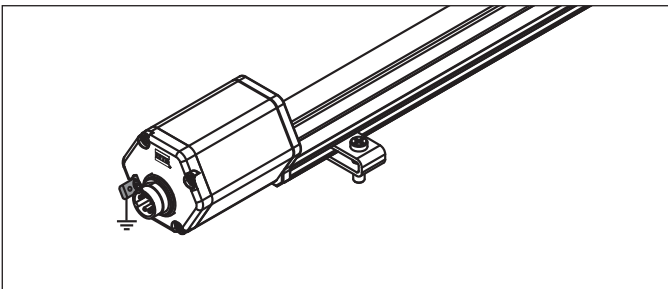


Fig. 47: Grounding via ground lug (e.g. profile sensor)

Connector wiring

Connect the sensor directly to the control system, indicator or other evaluating systems as follows:

D70 / HXX / PXX / RXX


M16 connector	Pin	Cable	Function
	1	GY	Data (-)
	2	PK	Data (+)
	3	YE	Clock (+)
	4	GN	Clock (-)
	5	BN	+24 VDC (-15 / +20 %)
	6	WH	DC Ground (0 V)
	7	-	Not connected

Fig. 48: Connector wiring D70 (M16) / HXX / PXX / RXX

FXX

Cable	Function
GY	Data (-)
PK	Data (+)
YE	Clock (+)
GN	Clock (-)
RD	+24 VDC (-15 / +20 %)
WH	DC Ground (0 V)
-	Not connected

Fig. 49: Connector wiring FXX

MSO


MS connector	Pin	Cable	Function
	A	WH	DC Ground
	B	-	Not connected
	C	GY	Data (-)
	D	PK	Data (+)
	E	RD	+24 VDC (-15 / +20 %)
	F	-	Not connected
	G	YE	Clock (+)
	H	GN	Clock (-)
	J	-	Not connected
	K	-	Not connected

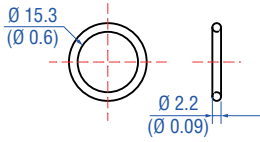
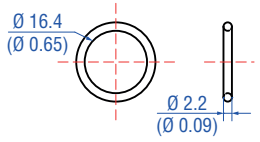
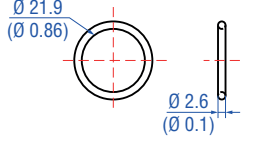
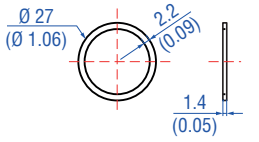
Fig. 50: Connector wiring MSO (MS)

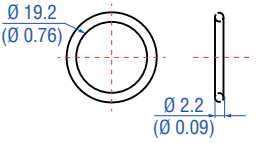
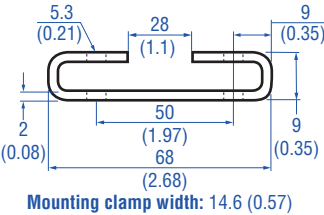
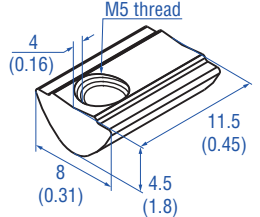
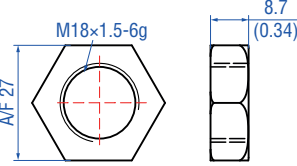
4.10 Frequently ordered accessories – Additional options available in our [Accessories Guide](#) 551 444

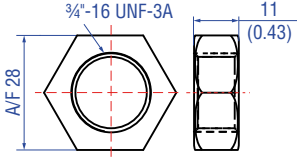
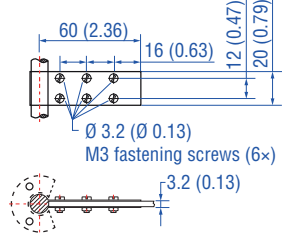
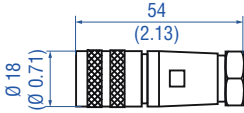
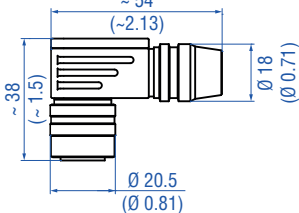
Position magnets			
<p>Magnet slider S Part no. 252 182</p>	<p>Magnet slider V Part no. 252 184</p>	<p>U-magnet OD33 Part no. 251 416-2</p>	<p>Ring magnet OD33 Part no. 201 542-2</p>
<p>For: RP</p> <p>Material: GFK, magnet hard ferrite Weight: Ca. 35 g Operating temperature: -40...+75 °C (-40...+167 °F)</p>	<p>For: RP</p> <p>Material: GFK, magnet hard ferrite Weight: Ca. 35 g Operating temperature: -40...+75 °C (-40...+167 °F)</p>	<p>For: RP, RH, RD4, RT4</p> <p>Material: PA ferrite GF20 Weight: Ca. 11 g Surface pressure: Max. 40 N/mm² Fastening torque for M4 screws: 1 Nm Operating temperature: -40...+105 °C (-40...+221 °F)</p>	<p>For: RH, RD4, RT4</p> <p>Material: PA ferrite GF20 Weight: Ca. 14 g Surface pressure: Max. 40 N/mm² Fastening torque for M4 screws: 1 Nm Operating temperature: -40...+105 °C (-40...+221 °F)</p>

Position magnets			
<p>Ring magnet OD25.4 Part no. 400 533</p>	<p>Ring magnet OD17.4 Part no. 401 032</p>	<p>Block magnet Part no. 403 448</p>	<p>Ring magnet Part no. 402 316</p>
<p>For: RH, RD4, RT4</p> <p>Material: PA ferrite Weight: Ca. 10 g Surface pressure: Max. 40 N/mm² Operating temperature: -40...+105 °C (-40...+221 °F)</p>	<p>For: RH, RD4, RT4</p> <p>Material: PA neobind Weight: Ca. 5 g Surface pressure: Max. 20 N/mm² Operating temperature: -40...+105 °C (-40...+221 °F)</p>	<p>For: RP, RH, RF</p> <p>Material: Hard ferrite Weight: Ca. 20 g Fastening torque for M4 screws: 1 Nm Operating temperature: -40...+75 °C (-40...+167 °F)</p>	<p>For: RH, RF, RD4</p> <p>Material: PA ferrite coated Weight: Ca. 13 g Surface pressure: 20 N/mm² Operating temperature: -40...+100 °C (-40...+212 °F)</p>

Position magnets		
<p>Ring magnet OD60 Part no. MT0162</p>	<p>U-magnet OD63.5 Part no. 201 553</p>	<p>Magnet spacer Part no. 400 633</p>
<p>For: RH, RF, RD4</p> <p>Material: Al CuMgPb, Magnets compound-filled Weight: Ca. 90 g Surface pressure: 20 N/mm² Fastening torque for M4 screws: 1 Nm Operating temperature: -40...+75 °C (-40...+167 °F)</p>	<p>For: RH, RF, RD4</p> <p>Material: PA 66-GF30, Magnets compound-filled Weight: Ca. 26 g Surface pressure: 20 N/mm² Fastening torque for M4 screws: 1 Nm Operating temperature: -40...+75 °C (-40...+167 °F)</p>	<p>For: RH, RD4, RT4</p> <p>Material: Aluminum Weight: Ca. 5 g Surface pressure: 20 N/mm² Fastening torque for M4 screws: 1 Nm</p>

Optional installation hardware			
			
O-ring for flange M18x1.5-6g Part no. 401 133	O-ring for flange 3/4"-16 UNF-3A Part no. 560 315	O-ring for pressure fit flange Part no. 560 705	Back-up ring for pressure fit flange Part no. 560 629
For: RH, RF, RD4, RT4	For: RH, RF, RD4, RT4	For: RD4	For: RD4
Application: Flange M18x1.5 Material: Fluoroelastomer 75 ± 5 durometer	Application: Flange 3/4"-16 UNF Material: Fluoroelastomer 75 ± 5 durometer	Application: Pressure fit flange Material: Nitrile rubber	Application: Pressure fit flange Material: Polymyte 90 durometer

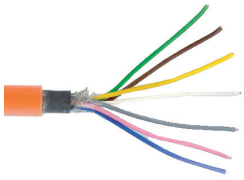
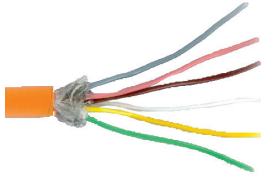
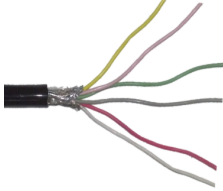

Optional installation hardware	Mounting clamp	T-slot nut	Optional installation hardware
			
O-ring for flange M22x1.5-6g Part no. 561 337	Mounting clamp Part no. 400 802	T-slot nut Part no. 401 602	Hex-jam nut M18 Part no. 500 018
For: RH	For: RP	For: RP	For: RH, RD4
Application: Flange M22x1.5 Material: FPM	Material: Stainless steel (AISI 304)	Fastening torque for M5 screw: 4.5 Nm	Application: M18x1.5 thread Material: Steel, 2 zinc, plated

Optional installation hardware	Cable connectors ¹³		
			
Hex-jam nut 3/4" Part no. 500 015	Fixing clip Part no. 561 481	M16 connector (7 pin) female, straight Part no. 370 624	M16 connector (7 pin) female, angled Part no. 560 779
For: RH, RD4	For: RH, RD4, RT4	For: RP, RH, RD4, RT4, RF	For: RP, RH, RD4, RT4, RF
Application: 3/4"-16 UNF thread Material: Zinc plated with nylon insert	Application: Used to secure sensor rods (Ø 10 mm (Ø 0.39 in.)) when using an U-magnet Material: Brass, non-magnetic	Material: Zinc nickel plated Termination: Solder Contact insert: Silver plated Cable Ø: 6...8 mm (0.24...0.31 in.) Operating temperature: -40...+100 °C (-40...+212 °F) Cable clamp: PG9 Ingress protection: IP65, IP67	Material: Zinc nickel plated Termination: Solder Contact insert: Silver plated Cable Ø: 6...8 mm (0.24...0.31 in.) Operating temperature: -40...+95 °C (-40...+203 °F) Ingress protection: IP67

¹³Follow the manufacturer's mounting instructions





Controlling design dimensions are in millimeters and measurements in () are in inches

Cables

			
TMPU cable Part no. 530 029	PUR cable Part no. 530 052	PUR cable Part no. 530 045	PVC cable Part no. 530 032
For: RP, RH, RD4, RT4, RF Name of cable in order code: P Material: TMPU jacket; orange Cable Ø: 6.5 mm (0.26 in.) Cross section: 7 × 0.14 mm ² Operating temperature: -20...+70 °C (-4...+158 °F)	For: RP, RH, RD4, RF Name of cable in order code: H Material: PUR jacket; orange Features: Twisted pair shielded Cable Ø: 6.4 mm (0.25 in.) Cross section: 3 × 2 × 0.25 mm ² Operating temperature: -30...+80 °C (-22...+176 °F)	For: RP, RH, RD4, RT4, RF Name of cable in order code: F Material: PUR jacket; black Cable Ø: 7.2 mm (0.28 in.) Cross section: 3 × 2 × 0.2 mm ² Operating temperature: -30...+80 °C (-22...+176 °F)	For: RP, RH, RD4, RT4, RF Name of cable in order code: R Material: PVC jacket; gray Features: Twisted pair shielded Cable Ø: 6 mm (0.24 in.) Dimensions: 3 × 2 × 0.14 mm ² Operating temperature: -10...+80 °C (-14...+176 °F)





Profile (RF)

Pressure rods (RF)

			
Profile with flange HFP [length mm: XXXXX] M HFP [length in.: XXXX.X] U	Pressure rod with flange M18×1.5-6g (flat-faced flange) HD [length mm: XXXX] M HD [length in.: XXX.X] U	Pressure rod with flange 3/4"-16 UNF-3A (flat-faced flange) HL [length mm: XXXX] M HL [length in.: XXX.X] U	Pressure rod with flange 3/4"-16 UNF-3A (raised-faced flange) HP [length mm: XXXX] M HP [length in.: XXX.X] U
For: RF-C Length: Max. 20,000 mm (787 in.) Ingress protection: IP30 Material: Aluminum See "Product Flash RF Profile" (document part number: 551442) for further information	For: RF-C Pressure rod Ø: 12.7 mm (0.5 in.) Length: 255...7500 mm (10...295 in.) Operating pressure: 350 bar (5076 psi) Material flange: Stainless steel 1.4305 (AISI 303) Material rod: Stainless steel 1.4301 (AISI 304) See technical bulletin "RF pressure housing pipe" (document part number: 551770) for further information	For: RF-C Pressure rod Ø: 12.7 mm (0.5 in.) Length: 255...7500 mm (10...295 in.) Operating pressure: 350 bar (5076 psi) Material flange: Stainless steel 1.4305 (AISI 303) Material rod: Stainless steel 1.4301 (AISI 304) See technical bulletin "RF pressure housing pipe" (document part number: 551770) for further information	For: RF-C Pressure rod Ø: 12.7 mm (0.5 in.) Length: 255...7500 mm (10...295 in.) Operating pressure: 350 bar (5076 psi) Material flange: Stainless steel 1.4305 (AISI 303) Material rod: Stainless steel 1.4301 (AISI 304) See technical bulletin "RF pressure housing pipe" (document part number: 551770) for further information

Flanges (RF)

Programming tools

			
Flange M18×1.5-6g Part no. 402 704	Flange 3/4"-16 UNF-3A Part no. 402 641	SSI display 6 digits Part no. IX 345 – IX 348	Programming kit Part no. 253 135-1 (EU) Part no. 253 310-1 (US)
For: RF-C Material: Stainless steel 1.4305 (AISI 303)	For: RF-C Material: Stainless steel 1.4305 (AISI 303)	For: RP, RH, RD4, RT4, RF Housing: 96 × 48 × 141 mm (3.78 × 1.89 × 5.55 in.) Cutout: 91 × 44 mm (3.58 × 1.73 in.)	For: RP, RH, RD4, RT4, RF Kit includes: interface converter box, power supply and cables Software is available at: www.temposonics.com

5. Operation

5.1 Getting started

The sensor is factory-set to its order sizes and adjusted, i.e. the start of the measuring range is specified in resolution steps.

Example: SSI value 51000 corresponds to a start of measuring range of 51 mm with a resolution of 1 µm

NOTICE If necessary, the SSI sensors can be re-adjusted using the service tool described below.

Diagnostic display

LEDs (red / green) in the sensor electronics housing lid provide information on the current sensor condition (Fig. 51).

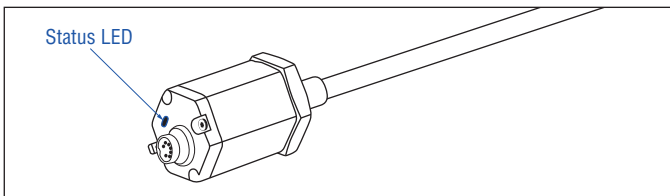


Fig. 51: LED display

LED status

Green	Red	Meaning
● ON	○ OFF	Normal function
● ON	● ON	No magnet / wrong quantity of magnets
● Flashing	● ON	Programming mode
● ON	● Flashing	Sensor not synchronous*

* for synchronous measurement only

NOTICE

Observe during commissioning

1. Before initial switch-on, check carefully if the sensor has been connected correctly.
2. Position the magnet in the measuring range of the sensor during first commissioning and after replacement of the magnet.
3. Ensure that the sensor control system cannot react in an uncontrolled way when switching on.
4. Ensure that the sensor is ready and in operation mode after switching on. The status LED lights permanently green.
5. Check the preset span start and end values of the measuring range (see Fig. 43 / Fig. 44) and correct them via the customer's control system or the Temposonics service tool. The operation of the service tool is described in detail on the following pages.

5.2 Programming and configuration

SSI interface

The interface of Temposonics® position sensors corresponds to SSI industry standard for absolute encoders. Its displacement value is encoded in a 24 / 25 / 26 bit binary or gray format and transmitted as a differential signal in SSI standard (RS 422) – independent of data width of the code (resolution).

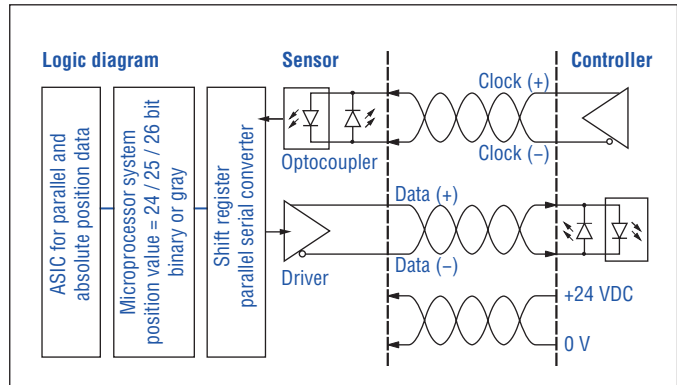


Fig. 52: Schematic connection

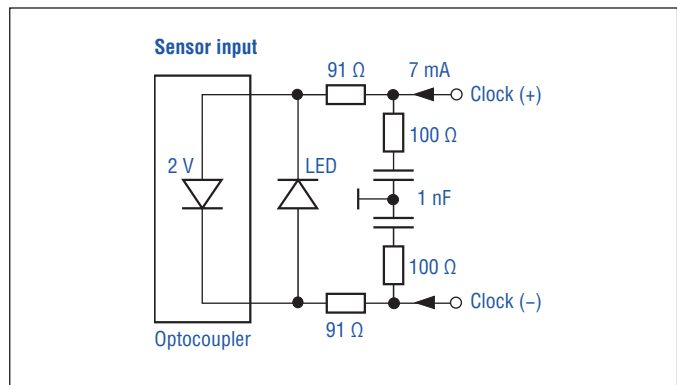


Fig. 53: Input wiring clock (+) / clock (-)

The absolute, parallel position data is continually updated by the sensor and converted by the shift-register into a serial bit stream (Fig. 54).

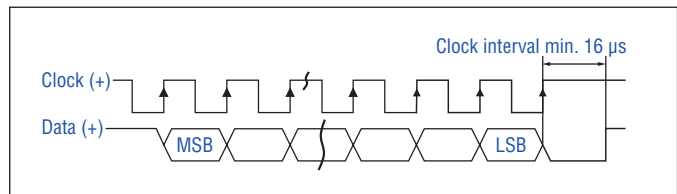


Fig. 54: Timing diagram

Dependent on the baud rate chosen in the controller the following cable lengths are possible (Fig. 55):

Cable length	< 3 m	< 50 m	< 100 m	< 200 m	< 400 m
Baud rate	1 MBd	< 400 kBd	< 300 kBd	< 200 kBd	< 100 kBd

Fig. 55: Cable lengths and related baud rates

Temposonics service tool

Temposonics® position sensors can be adapted to modified measurement tasks very easily from outside via the connecting leads – without opening the sensor. For this, the following Temposonics programming tool is available (see page 41).

Programming kit, part no. 253 135-1 (EU) / 253 310-1 (US)

The PC programmer is a hardware converter between sensor and serial PC interface. It can be used for adjusting sensor parameters via computer and the Temposonics programming software. The software for reading and adjusting the sensors requires a Windows computer with a free USB port. You can adjust the following parameters:

- Data length and data format (optionally with parity- and error bit)
- Resolution and measuring direction
- Synchronous / asynchronous measurement
- Offset, begin of the measurement range
- Alarm value (magnet was removed, magnet is missing)
- Measurement filter (moving average of 2, 4 or 8 measurements for noise reduction)
- Velocity measurement or position measurement or differentiation measurement

Step 1: Connect PC programmer

- Step 2: Install software
- Step 3: Start program

- Connect the PC programmer with the sensor via the corresponding adapter cable.
- Connect the PC programmer to an USB port of the computer.
- Connect the power supply via connector.

The outer contact of the connector is 0 V (ground), the inner contact is 24 VDC.

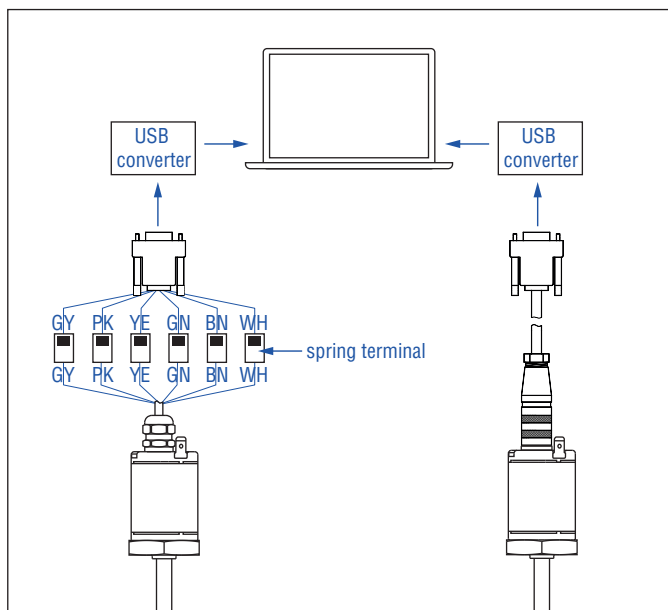


Fig. 56: Connect PC programmer
(for sensors with cable outlet on the left, for sensors with connector outlet on the right)

NOTICE

Never connect / disconnect the sensor when voltage is applied.

- Step 1: Connect PC programmer
- Step 2: Install software
- Step 3: Start program

Download current software version from www.temposonics.com. Copy the program SSIConfigurator.exe to your computer and start it by double-clicking on it. The program now displays a list of available COMs. Normally, the COM port with the lowest number (e.g. COM1) should be selected. If a connection fails, it could be a missing driver. In this case, download and install the USB serial converter driver from www.temposonics.com.

- Step 1: Connect PC programmer
- Step 2: Install software
- Step 3: Start program

After starting the MTS SSI-Configurator, the user interface of the connected sensor with its adjustable parameters will open (Fig. 57).

MTS SSI-Configurator user interface

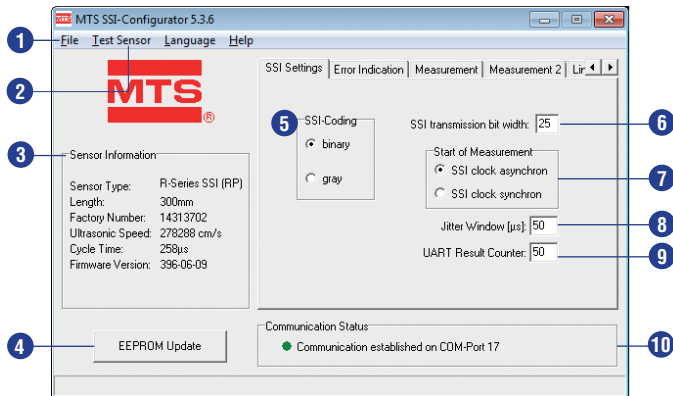


Fig. 57: MTS SSI-Configurator, SSI Settings

- 1 In the **File** menu, you can save the sensor configuration on hard disk, print it out or load it into the sensor. Moreover, this menu permits returning to the factory setting.
- 2 Via **Test Sensor** the position of the magnet is displayed graphically. (Fig. 58).
- 3 Frame **Sensor Information** contains the invariable sensor parameters, which are read in automatically when connecting the sensor.
- 4 Click on **EEPROM Update** to send and store altered parameters (highlighted with a blue background) permanently in the sensor. Subsequently, the stored values are displayed again with a white background.
- 5 Use the option box **binary** or **gray** to determine the SSI coding.
- 6 In this field you can set the **SSI transmission bit width** for the position output.
- 7 Use the option box **SSI clock asynchron** and **SSI clock synchron** to change the start of measurement.

MTS SSI-Configurator		R-Series order code
SSI clock asynchron	complies with	Asynchronous mode
SSI clock synchron	complies with	Synchronous mode 1

In asynchronous mode the sensor starts measuring and provides the position independent of the PLC.

In synchronous mode 1 the output of the position of the Temposonics® SSI sensor is matched to the data request cycle of the controller. The contouring error complies with the cycle time of the stroke length.

- 8 The jitter specifies the time interval between the start of measuring and the SSI clock, which is given by the PLC (for “SSI clock synchron”).
- 9 Via **UART Result Counter** you define a time interval for the function **Test Sensor** to send a position value Fig. 58 (graphical presentation of position values). Example: If you choose “50” in the field **UART Result Counter**, each 50. measurement will be displayed.
- 10 **Communication Status** indicates that the sensor is connected successfully.

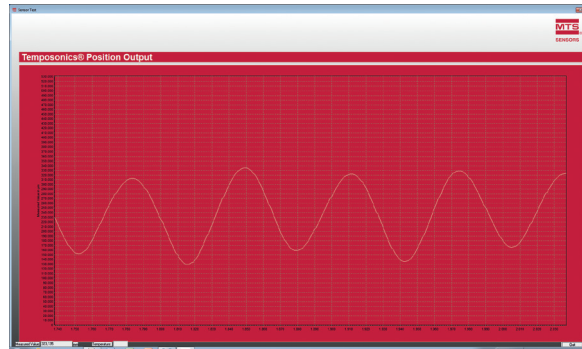


Fig. 58: Graphical display of position values via Test Sensor

Tab “Error Indication”

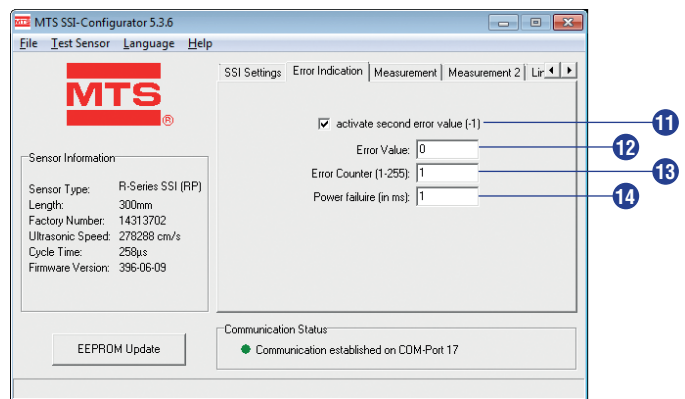


Fig. 59: MTS SSI-Configurator, Error Indication

- 11 If the check box **activate second error value (-1)** is active, an error value of “-1” is output if the sensor is used with more magnets as specified before. If the check box is not active and the sensor is used with more magnets as specified before, the value which was defined in field **Error Value** will be displayed. The **Error Value** will also display if the sensor is used with less magnets as determined before.
- 12 In the case of failure the sensor transmits the **Error Value**.
- 13 Use the field **Error Counter** to determine how often in the case of failure (1...255 times) the old measurement value will be repeated, before the **Error Value** will be displayed.

MTS SSI-Configurator		R-Series order code
Error counter	complies with	Error delay

- 14 In this field you can define a period (1...100 ms), during which the power supply of the sensor can be fallen short of, without the **Error Value** to display. Set the value to “0” to deactivate the function **Power failure (in ms)**.

Tab “Measurement”

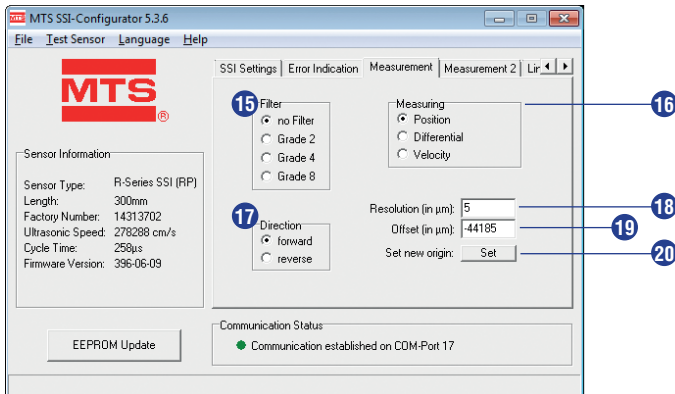


Fig. 60: MTS SSI-Configurator, Measurement

- 15 Use the field **Filter** to choose a noise reduction filter of two, four or eight measurements. The RT4 is supplied with a noise reduction filter. You can adjust the filter via the MTS SSI-Configurator and adapt it to your application.
- 16 In the field **Measuring** you can choose between the following options:
Position: Measurement and output of position value
Differential: Measurement of two positions and output of the distance between them.
Velocity: Measurement and output of velocity of the position magnet, which moves over the sensor rod or the sensor profile.
- 17 Via **Direction** you can determine the measuring direction.
Forward: Ascending position values from sensor electronics housing to rod end
Reverse: Ascending position values from rod end to sensor electronics housing
- 18 In the field **Resolution (in µm)** you can set the resolution of the sensor. See technical data starting on page 47 for resolution steps.
- 19 **Offset (in µm)** shows the offset which was determined during the sensor end control at the factory. You can change the offset (null position) in entering a new value in the field **Offset (in µm)**. After that you have to press the button **EEPROM Update** to confirm. Another possibility is described in 20.
- 20 If you like to change the offset, move the magnet into the desired position. Confirm the position via the button **Set**.
 The factory settings can be restored at any time under the menu item **File**.

NOTICE If the measuring direction changes, the offset will be converted automatically. If the null position moves into the measuring range, values < 0 of the binary data format will be output as negative.

Tab “Measurement 2”

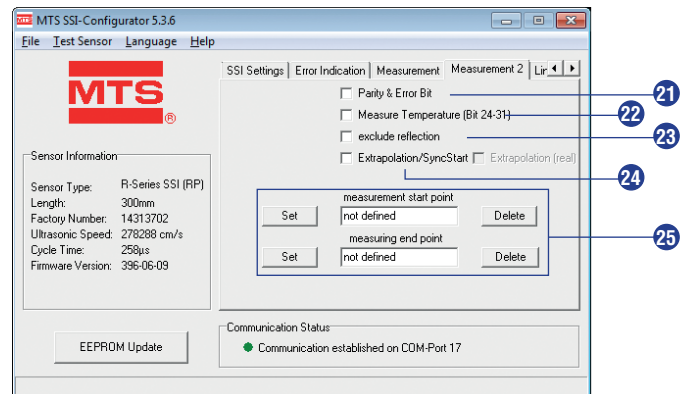


Fig. 61: MTS SSI-Configurator, Measurement 2

- 21

MTS SSI-Configurator	R-Series order code
Parity bit	complies with Parity even bit: 26 bit
Error bit	complies with Alarm bit: 25 bit
- If the check box is activated, bit 25 is output as error bit and bit 26 as parity bit. In this case the SSI bit width for transferring the position data is limited to 24 bit. The **Parity & Error Bit** influences the cycle time of the synchronous measurement. You cannot choose **Parity & Error Bit** and **Measure Temperature (Bit 24-31)** at the same time.
- 22 If the checkbox is activated the temperature measured in the sensor electronics housing will be output (bit 25-32). In this case the SSI bit width for transferring the position data is limited to 24 bit. You cannot choose **Parity & Error Bit** and **Measure Temperature (Bit 24-31)** at the same time.
- 23 Activate the check box to exclude reflections of the position measurement. Thus the cycle time extends. This applies only to sensors without “internal linearization”. For sensors with option “internal linearization” the check box “Internal linearization” displays. Via the check box you can activate or deactivate the “internal linearization”.
- 24 To select the “synchronous mode 2” activate **SSI clock synchron** in SSI settings first. After that activate the check box **Extrapolation/SyncStart**.

MTS SSI-Configurator	R-Series order code
Extrapolation/SyncStart	complies with Synchronous mode 2
- The “synchronous mode 2” is most suitable for applications where the polling cycle of the controller can be faster than the measurement cycle time of the Temposonics® SSI sensor. The values for the PLC will be oversampled up to 10 kHz. The delay is similar to the asynchronous mode.
- 25 In the field **measurement start point** and **measurement end point** you can define a new working area. Move the magnet to the desired position and click **Set** to define a new measurement start or end point. Via the button **Delete** you can delete the measurement start and end point again. The current position of the magnet is displayed within the working area, a magnet outside of the working area will be ignored.

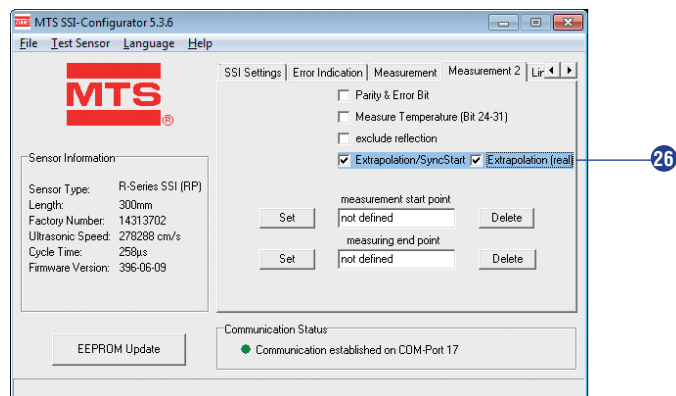


Fig. 62: MTS SSI-Configurator, Measurement 2, choose synchronous mode 3

- 26 To select the “synchronous mode 3”, activate the check box **Extrapolation/SyncStart** first and after that **Extrapolation (real)**. The function of the “synchronous mode 3” is similar to “synchronous mode 2”. For “synchronous mode 3” each delay will be compensated.

MTS SSI-Configurator	R-Series order code
Extrapolation (real) complies with	Synchronous mode 3

6. Maintenance and troubleshooting

6.1 Error conditions, troubleshooting

See “Fig. 51: LED display” on page 42.

6.2 Maintenance

The sensor is maintenance-free.

6.3 Repair

Repairs of the sensor may only be performed by Temposonics or a repair facility explicitly authorized by Temposonics.

6.4 List of spare parts

No spare parts are available for this sensor.

6.5 Transport and storage

The conditions of transport and storage of the sensor match the operating conditions mentioned in this document.

7. Removal from service / dismantling

The product contains electronic components and must be disposed of in accordance with the local regulations.

8. Technical data

8.1 Technical data of Temposonics® RP

Output

Interface	SSI (Synchronous Serial Interface) – differential signal in SSI standard (RS 422)												
Data format	Binary or gray, optional parity and error bit or temperature of sensor electronics												
Data length	8...32 bit												
Data transmission rate	70 kBaud* ... 1 MBaud, depending on cable length: <table border="1"> <tr> <td>Cable length</td> <td>< 3 m</td> <td>< 50 m</td> <td>< 100 m</td> <td>< 200 m</td> <td>< 400 m</td> </tr> <tr> <td>Baud rate</td> <td>1 MBd</td> <td>< 400 kBd</td> <td>< 300 kBd</td> <td>< 200 kBd</td> <td>< 100 kBd</td> </tr> </table>	Cable length	< 3 m	< 50 m	< 100 m	< 200 m	< 400 m	Baud rate	1 MBd	< 400 kBd	< 300 kBd	< 200 kBd	< 100 kBd
Cable length	< 3 m	< 50 m	< 100 m	< 200 m	< 400 m								
Baud rate	1 MBd	< 400 kBd	< 300 kBd	< 200 kBd	< 100 kBd								
Measured value	Position, differentiation measurement, velocity, temperature of sensor electronics												

Measurement parameters

Resolution	Position: 0.5 µm, 1 µm, 2 µm, 5 µm, 10 µm, 20 µm, 50 µm, 100 µm / Velocity over 10 measured values: 0.1 mm/s (at 1 ms cycle time)
Cycle time	Stroke length 300 mm 750 mm 1000 mm 2000 mm 5000 mm Measurement rate 3.7 kHz 3.0 kHz 2.3 kHz 1.2 kHz 0.5 kHz
Linearity ¹⁴	< ±0.01 % F.S. (minimum ±40 µm) Option internal linearization Linearity tolerance: < 300 mm: typ. ±15 µm, max. ±25 µm 300 ... 600 mm: typ. ±20 µm, max. ±30 µm 600...1200 mm: typ. ±30 µm, max. ±50 µm 1200...3000 mm: typ. ±45 µm, max. ±90 µm 3000...5000 mm: typ. ±85 µm, max. ±150 µm
Repeatability	< ±0.001 % F.S. (minimum ±2.5 µm) typical
Hysteresis	< 4 µm typical
Temperature coefficient	< 15 ppm / K typical

Operating conditions

Operating temperature	-40...+75 °C (-40...+167 °F)
Humidity	90 % rel. humidity, no condensation
Ingress protection ¹⁵	IP65
Shock test	100 g (single shock), IEC standard 60068-2-27
Vibration test	15 g / 10...2000 Hz, IEC standard 60068-2-6 (resonance frequencies excluded) option: Vibration resistant 30 g (av)
EMC test	Electromagnetic emission according to EN 61000-6-3 Electromagnetic immunity according to EN 61000-6-2 The sensor meets the requirements of the EC directives and is marked with CE
Magnet movement velocity	Magnet slider: Max. 10 m/s; U-magnet: Any; block magnet: Any

Design / Material

Sensor electronics housing	Aluminum
Sensor profile	Aluminum
Stroke length	25...5080 mm (1...200 in.)

Mechanical mounting

Mounting position	Any orientation
Mounting instruction	Please consult the technical drawings on page 17

See next page for section "Electrical connection"

*/With standard one shot of 16 µs

¹⁴/With position magnet # 252 182

¹⁵/The IP rating is not part of the UL recognition

Electrical connection

Connection type	M16 (7 pin) male connector or cable outlet
Operating voltage	+24 VDC (-15 / +20 %); UL Recognition requires an approved power supply with energy limitation (UL 61010-1), or Class 2 rating according to the National Electrical Code (USA) / Canadian Electrical Code.
Ripple	$\leq 0.28 V_{pp}$
Current consumption	100 mA typical
Dielectric strength	500 VDC (DC ground to machine ground)
Polarity protection	Up to -30 VDC
Overvoltage protection	Up to 36 VDC

8.2 Technical data of Temposonics® RH

Output

Interface	SSI (Synchronous Serial Interface) – differential signal in SSI standard (RS 422)												
Data format	Binary or gray, optional parity and error bit or temperature of sensor electronics												
Data length	8...32 bit												
Data transmission rate	70 kBaud* ... 1 MBaud, depending on cable length: <table> <tr> <td>Cable length</td> <td>< 3 m</td> <td>< 50 m</td> <td>< 100 m</td> <td>< 200 m</td> <td>< 400 m</td> </tr> <tr> <td>Baud rate</td> <td>1 MBd</td> <td>< 400 kBd</td> <td>< 300 kBd</td> <td>< 200 kBd</td> <td>< 100 kBd</td> </tr> </table>	Cable length	< 3 m	< 50 m	< 100 m	< 200 m	< 400 m	Baud rate	1 MBd	< 400 kBd	< 300 kBd	< 200 kBd	< 100 kBd
Cable length	< 3 m	< 50 m	< 100 m	< 200 m	< 400 m								
Baud rate	1 MBd	< 400 kBd	< 300 kBd	< 200 kBd	< 100 kBd								
Measured value	Position, differentiation measurement, velocity, temperature of sensor electronics												

Measurement parameters

Resolution	Position: 0.5 µm, 1 µm, 2 µm, 5 µm, 10 µm, 20 µm, 50 µm, 100 µm / Velocity over 10 measured values: 0.1 mm/s (at 1 ms cycle time)
Cycle time	Stroke length 300 mm 750 mm 1000 mm 2000 mm 5000 mm Measurement rate 3.7 kHz 3.0 kHz 2.3 kHz 1.2 kHz 0.5 kHz
Linearity ¹⁶	< ±0.01 % F.S. (minimum ±40 µm) Option internal linearization Linearity tolerance: < 300 mm: typ. ±15 µm, max. ±25 µm 300...600 mm: typ. ±20 µm, max. ±30 µm 600...1200 mm: typ. ±30 µm, max. ±50 µm
Repeatability	< ±0.001 % F.S. (minimum ±2.5 µm) typical
Hysteresis	< 4 µm typical
Temperature coefficient	< 15 ppm / K typical

Operating conditions

Operating temperature	-40...+75 °C (-40...+167 °F)
Humidity	90 % rel. humidity, no condensation
Ingress protection ¹⁷	IP67, IP68 for cable outlet
Shock test	100 g (single shock) IEC standard 60068-2-27
Vibration test	15 g / 10...2000 Hz, IEC standard 60068-2-6 (resonance frequencies excluded) option: Vibration resistant 30 g (av)
EMC test	Electromagnetic emission according to EN 61000-6-3 Electromagnetic immunity according to EN 61000-6-2 The sensor meets the requirements of the EC directives and is marked with CE
Magnet movement velocity	Any

Design / Material

Sensor electronics housing	Aluminum
Sensor rod	Stainless steel 1.4306 (AISI 304L)
Stroke length	25...7620 mm (1...300 in.)
Operating pressure	350 bar (5076 psi), 700 bar (10153 psi) peak (at 10 × 1 min)

Mechanical mounting

Mounting position	Any orientation
Mounting instruction	Please consult the technical drawings on page 18

See next page for section "Electrical connection"

* / With standard one shot of 16 µs

¹⁶/With position magnet # 251 416-2

¹⁷/The IP rating is not part of the UL recognition

Electrical connection

Connection type	M16 (7 pin) male connector or cable outlet
Operating voltage	+24 VDC (-15 / +20 %); UL Recognition requires an approved power supply with energy limitation (UL 61010-1), or Class 2 rating according to the National Electrical Code (USA) / Canadian Electrical Code.
Ripple	$\leq 0.28 V_{pp}$
Current consumption	100 mA typical
Dielectric strength	500 VDC (DC ground to machine ground)
Polarity protection	Up to -30 VDC
Overvoltage protection	Up to 36 VDC

8.3 Technical data of Temposonics® RD4

Output

Interface	SSI (Synchronous Serial Interface) – differential signal in SSI standard (RS 422)												
Data format	Binary or gray, optional parity and error bit or temperature of sensor electronics												
Data length	8...32 bit												
Data transmission rate	70 kBaud*...1 MBaud, depending on cable length: <table> <tr> <td>Cable length</td> <td>< 3 m</td> <td>< 50 m</td> <td>< 100 m</td> <td>< 200 m</td> <td>< 400 m</td> </tr> <tr> <td>Baud rate</td> <td>1 MBd</td> <td>< 400 kBd</td> <td>< 300 kBd</td> <td>< 200 kBd</td> <td>< 100 kBd</td> </tr> </table>	Cable length	< 3 m	< 50 m	< 100 m	< 200 m	< 400 m	Baud rate	1 MBd	< 400 kBd	< 300 kBd	< 200 kBd	< 100 kBd
Cable length	< 3 m	< 50 m	< 100 m	< 200 m	< 400 m								
Baud rate	1 MBd	< 400 kBd	< 300 kBd	< 200 kBd	< 100 kBd								
Measured value	Position, differentiation measurement, velocity, temperature of sensor electronics												

Measurement parameters

Resolution	Position: 1 µm, 2 µm, 5 µm, 10 µm, 20 µm, 50 µm, 100 µm / Velocity over 10 measured values: 0.1 mm/s (at 1 ms cycle time)
Cycle time	Stroke length 300 mm 750 mm 1000 mm 2000 mm 5000 mm Measurement rate 3.7 kHz 3.0 kHz 2.3 kHz 1.2 kHz 0.5 kHz
Linearity ¹⁸	< ±0.02 % F.S. (minimum ±50 µm) ¹⁹
Repeatability	< ±0.001 % F.S. (minimum ±2.5 µm) typical
Hysteresis	< 4 µm typical

Operating conditions

Operating temperature	-40...+75 °C (-40...+167 °F)
Humidity	90 % rel. humidity, no condensation
Ingress protection	Sensor electronics: IP67 (with professionally mounted housing and connectors) Rod with connecting cable for side cable entry: IP65 Rod with single wires and flat connector with bottom cable entry: IP30
Shock test	100 g (single shock) IEC standard 60068-2-27
Vibration test	10 g / 10...2000 Hz IEC standard 60068-2-6 (resonance frequencies excluded)
EMC test ²⁰	Electromagnetic emission according to EN 61000-6-3 Electromagnetic immunity according to EN 61000-6-2
Magnet movement velocity	Any

Design / Material

Sensor electronics housing	Aluminum
Sensor rod	Stainless steel 1.4306 (AISI 304L)
Stroke length	25...5080 mm (1...200 in.)
Operating pressure	350 bar (5076 psi), 700 bar (10153 psi) peak (at 10 × 1 min)

Mechanical mounting

Mounting position	Any orientation
Mounting instruction	Please consult the technical drawings on page 21 and on page 23

See next page for section "Electrical connection"

* / With standard one shot of 16 µs

¹⁸/With position magnet # 251 416-2

¹⁹/For pressure fit flange »S« the linearity deviation can be higher in the first 30 mm (1.2 in.) of stroke length

²⁰/Sensor rod and connecting cable have to be mounted in a metal housing (e.g. in a cylinder)

Electrical connection

Connection type	M16 (7 pin) male connector or cable outlet
Operating voltage	+24 VDC (-15 / +20 %)
Ripple	$\leq 0.28 V_{pp}$
Current consumption	100 mA typical
Dielectric strength	500 VDC (DC ground to machine ground)
Polarity protection	Up to -30 VDC
Overvoltage protection	Up to 36 VDC

8.4 Technical data of Temposonics® RT4

Output

Interface	SSI (Synchronous Serial Interface) – differential signal in SSI standard (RS 422)				
Data format	Binary or gray, optional: parity and error bit				
Data length	24, 25 or 26 bit				
Data transmission rate	70 kBaud* ... 1 MBaud, depending on cable length:				
	Cable length	< 3 m	< 50 m	< 100 m	< 200 m < 400 m
	Baud rate	1 MBd	< 400 kBd	< 300 kBd	< 200 kBd < 100 kBd
Measured value	Position				

Measurement parameters

Resolution	1 µm, 2 µm, 5 µm, 10 µm, 20 µm, 50 µm, 100 µm				
Cycle time	Stroke length	300 mm	750 mm	1000 mm	2000 mm
	Measurement rate	3.7 kHz	3.0 kHz	2.3 kHz	1.2 kHz
Linearity ²¹	< ±0.02 % F.S. (minimum ±50 µm)				
Repeatability	< ±0.001 % F.S. (minimum ±2.5 µm) typical				

Operating conditions

Operating temperature	Sensor electronics: -40...+75 °C (-40...+167 °F) Sensor rod with interconnection cable: -40...+100 °C (-40...+ 212 °F)
Humidity	90 % rel. humidity, no condensation
Ingress protection	Sensor electronics: IP67 (with professionally mounted housing and connectors) Sensor housing with interconnection cable: IP68
Shock test	100 g (single shock) IEC standard 60068-2-27
Vibration test	5 g / 10...2000 Hz IEC standard 60068-2-6 (resonance frequencies excluded)
EMC test ²²	Electromagnetic emission according to EN 61000-6-3 Electromagnetic immunity according to EN 61000-6-2 The sensor meets the requirements of the EC directives if note “21” is followed
Magnet movement velocity	Any

Design / Material

Sensor electronics housing	Aluminum
Sensor housing	Stainless steel 1.4305 (AISI 303)
Stroke length	25...2540 mm (1...100 in.)
Operating pressure	350 bar (5076 psi) static, 690 bar (10008 psi) peak

Mechanical mounting

Mounting position	Any orientation
Mounting instruction	Please consult the technical drawings on page 27

See next page for section “Electrical connection”

* / With standard one shot of 16 µs
²¹ / With position magnet # 251 416-2
²² / Sensor rod and connecting cable have to be mounted in a metal housing (e.g. in a cylinder)

Electrical connection

Connection type	M16 (7 pin) male connector or integral cable
Operating voltage	+24 VDC (-15 / +20 %)
Ripple	$\leq 0.28 V_{pp}$
Current consumption	100 mA typical per sensor electronics
Dielectric strength	500 VDC (DC ground to machine ground)
Polarity protection	Up to -30 VDC
Overvoltage protection	Up to 36 VDC

8.5 Technical data of Temposonics® RF

Output

Interface	SSI (Synchronous Serial Interface) – differential signal in SSI standard (RS 422)												
Data format	Binary or gray, optional parity and error bit or temperature of sensor electronics												
Data length	8...32 bit												
Data transmission rate	70 kBaud* ... 1 MBaud, depending on cable length: <table> <tr> <td>Cable length</td> <td>< 3 m</td> <td>< 50 m</td> <td>< 100 m</td> <td>< 200 m</td> <td>< 400 m</td> </tr> <tr> <td>Baud rate</td> <td>1 MBd</td> <td>< 400 kBd</td> <td>< 300 kBd</td> <td>< 200 kBd</td> <td>< 100 kBd</td> </tr> </table>	Cable length	< 3 m	< 50 m	< 100 m	< 200 m	< 400 m	Baud rate	1 MBd	< 400 kBd	< 300 kBd	< 200 kBd	< 100 kBd
Cable length	< 3 m	< 50 m	< 100 m	< 200 m	< 400 m								
Baud rate	1 MBd	< 400 kBd	< 300 kBd	< 200 kBd	< 100 kBd								
Measured value	Position, differentiation measurement, velocity, temperature of sensor electronics												

Measurement parameters

Resolution	Position: 2 µm, 5 µm, 10 µm, 20 µm, 50 µm, 100 µm / Velocity over 10 measured values: 0.1 mm/s (at 1 ms cycle time)
Cycle time	Stroke length 300 mm 750 mm 1000 mm 2000 mm 5000 mm 10,000 mm 20,000 mm Measurement rate 3.7 kHz 3.0 kHz 2.3 kHz 1.2 kHz 0.5 kHz 0.25 kHz 0.125 kHz
Linearity ²³	< ±0.02 % F.S. (minimum ±100 µm)
Repeatability	< ±0.001 % F.S. (minimum ±2.5 µm) typical
Hysteresis	< 4 µm typical

Operating conditions

Operating temperature	-40...+75 °C (-40...+167 °F)
Humidity	90 % rel. humidity, no condensation ²⁴
Ingress protection	IP30 (IP65 rating only for professional mounted guide pipe and if mating connectors are correctly fitted)
Shock test	100 g (single shock) IEC standard 60068-2-27
Vibration test	5 g / 10...150 Hz IEC standard 60068-2-6 (resonance frequencies excluded)
EMC test ²⁵	Electromagnetic emission according to EN 61000-6-3 Electromagnetic immunity according to EN 61000-6-2 The sensor meets the requirements of the EC directives and is marked with CE
Magnet movement velocity	Any

Design / Material

Sensor electronics housing	Aluminum
Sensor rod	Stainless steel conduit with PTFE coating
Stroke length	150...20,000 mm (6...787 in.)
Operating pressure	350 bar (5076 psi) for RF with pressure rod HD / HL / HP (see accessories on page 39)

Mechanical mounting

Mounting position	Any orientation
Mounting instruction	Please consult the technical drawings on page 31

See next page for section "Electrical connection"

* / With standard one shot of 16 µs

²³/With position magnet # 251 416-2

²⁴/For professional mounted guide pipe and if mating connectors are correctly fitted

²⁵/The conformity is fulfilled, assumed the wave guide of the sensor is embedded in an EMC-sealed and grounded housing

Electrical connection

Connection type	M16 (7 pin) male connector or cable outlet
Operating voltage	+24 VDC (-15 / +20 %)
Ripple	$\leq 0.28 V_{pp}$
Current consumption	100 mA typical
Dielectric strength	500 VDC (DC ground to machine ground)
Polarity protection	Up to -30 VDC
Overvoltage protection	Up to 36 VDC

9. Appendix

Safety Declaration

Dear Customer,

If you return one or several sensors for checking or repair, we need you to sign a safety declaration. The purpose of this declaration is to ensure that the returned items do not contain residues of harmful substances and / or that people handling these items will not be in danger.

Temposonics order number: _____ Sensor type(s): _____

Serial number(s): _____ Sensor length(s): _____

The sensor has been in contact with the following materials:

Do not specify chemical formulas.
Please include safety data sheets of the substances, if applicable.

In the event of suspected penetration of substances into the sensor, consult Temposonics to determine measures to be taken before shipment.

Short description of malfunction:

Corporate information

Company: _____

Address: _____

Contact partner

Name: _____

Phone: _____

E-mail: _____

We hereby certify that the measuring equipment has been cleaned and neutralized.
Equipment handling is safe. Personnel exposure to health risks during transport and repair is excluded.

Stamp

GERMANY
Temposonics
GmbH & Co. KG
Auf dem Schüffel 9
58513 Lüdenscheid, Germany

Tel. + 49-23 51-95 87 0
Fax. + 49-23 51-5 64 91
info.de@temposonics.com
www.temposonics.com

Signature

USA
Temposonics, LCC.
3001 Sheldon Drive Cary,
N.C. 27513, USA

Tel. +1 919 677-0100
Fax +1 919 677-0200
info.us@temposonics.com
www.temposonics.com

Date

JAPAN
Temposonics
737 Aihara-machi,
Machida-shi,
Tokyo 194-0211, Japan

Tel. + 81 42 775-3838
Fax + 81 42 775-5512
info.jp@temposonics.com
www.temposonics.com

UNITED STATES
Temposonics, LLC.
Americas & APAC Region
3001 Sheldon Drive
Cary, N.C. 27513
Phone: +1 919 677-0100
E-mail: info.us@temposonics.com

GERMANY
Temposonics
GmbH & Co. KG
EMEA Region & India
Auf dem Schüffel 9
58513 Lüdenscheid
Phone: +49 2351 9587-0
E-mail: info.de@temposonics.com

ITALY
Branch Office
Phone: +39 030 988 3819
E-mail: info.it@temposonics.com

FRANCE
Branch Office
Phone: +33 1 58 4390-28
E-mail: info.fr@temposonics.com

UK
Branch Office
Phone: +44 79 44 15 03 00
E-mail: info.uk@temposonics.com

SCANDINAVIA
Branch Office
Phone: +46 70 29 91 281
E-mail: info.sca@temposonics.com

CHINA
Branch Office
Phone: +86 21 2415 1000 / 2415 1001
E-mail: info.cn@temposonics.com

JAPAN
Branch Office
Phone: +81 3 6416 1063
E-mail: info.jp@temposonics.com

Document Part Number:
551686 Revision B (EN) 10/2018



temposonics.com